

# Typ **TSA5 H<sub>2</sub>**

**WEH<sup>®</sup> Breakaway Coupling**  
for bus and truck fuelling stations

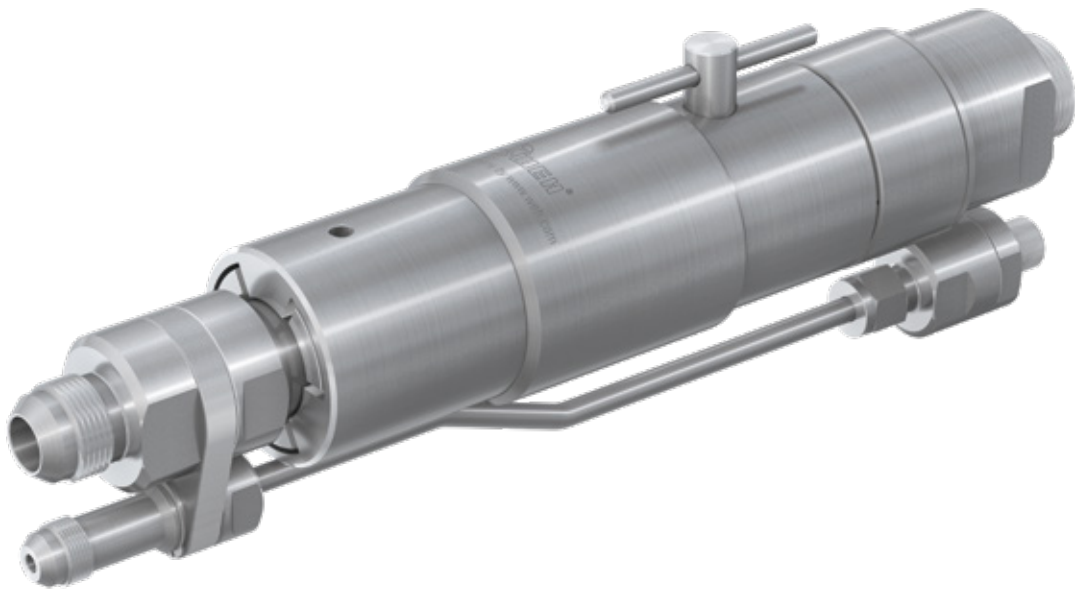

**General**

**DESCRIPTION**

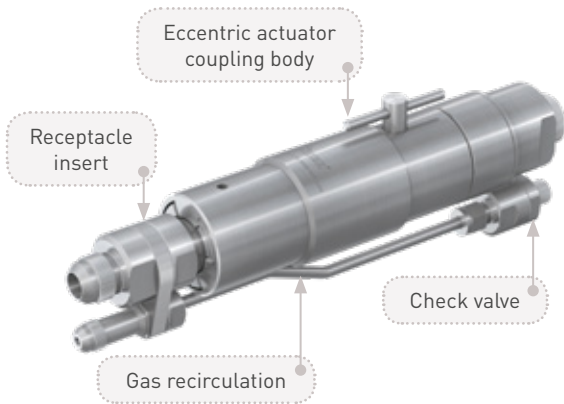

**Features**

- Re-usable without factory reservicing
- Installation at the dispenser
- Small compact design
- Integrated cleanable filter (40 micron)
- Check valve at venting line
- No additional tool necessary

The WEH® TSA5 H<sub>2</sub> Breakaway Coupling offers additional safety for your bus and truck fuelling station. The breakaway is installed between the dispenser and the filling/venting hose. In the event of accidental deployment, e.g. driving a vehicle from the dispenser with the nozzle remaining in the vehicle fuel port, the coupling will separate the connections between dispenser and hose sealing both ends. This protects largely the receptacle, the fuelling nozzle and the dispenser against damage. The detached coupling can be easily reattached and placed back in service after having been function tested. The integrated filter provides clean hydrogen and is easy to maintain. The WEH® Breakaway Coupling consists of a coupling body, a receptacle insert and a gas recirculation with check valve.

On request we also offer complete nozzle-hose-assemblies consisting of a fuelling nozzle, a hose set and a breakaway coupling.

**Application**

Breakaway coupling for bus and truck fuelling stations for direct installation at the dispenser.

**TECHNICAL DATA**

Characteristic	Basic version	Options
Nominal bore DN	12 mm	On request
Pressure range	PN = 350 bar (5,000 psi)   PS = 450 bar   PT = 675 bar	
Temperature range	-40 °C up to +85 °C (-40 °F up to +185 °F)	On request
Breakaway force	300 - 600 N	On request
Material	Corrosion resistant stainless steel, aluminium	On request
Sealing material	Hydrogen compatible	On request
Design	With gas recirculation and filter (40 micron)	On request

**Ordering**

**ORDERING** | WEH® TSA5 H<sub>2</sub> Breakaway Coupling with gas recirculation

approx. dimensions (mm)

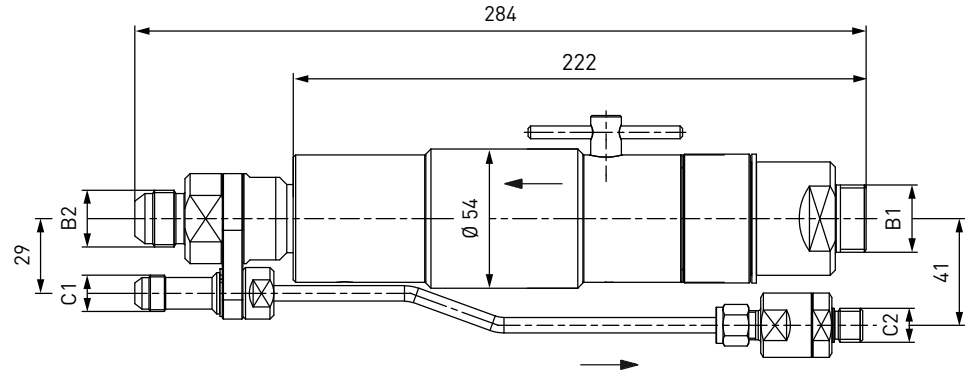

Part No.	Description	DN	Pressure (PN)	B1 (external thread)	B2 (external thread)	C1 (external thread)	C2 (external thread)
<b>C1-17941-X7-X01</b>	TSA5 H <sub>2</sub> with filter (40 micron)	12	350 bar / 5,000 psi	G3/4"	UNF 7/8"-14*	UNF 9/16"-18*	G1/4"

\* acc. to SAE J514, 37°

## Accessories

### ACCESSORIES

The following accessories are available for the WEH® TSA5 H<sub>2</sub> Breakaway Coupling:

#### Dispenser mounting for breakaway coupling

The breakaway coupling can also be used with a dispenser mounting. The mounting is firmly attached to the dispenser. The integrated guide tube provides a straight pull-off force. The dispenser mounting can be used instead of a return pulley (hose pulley).

approx. dimensions (mm)

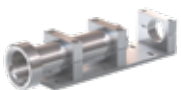
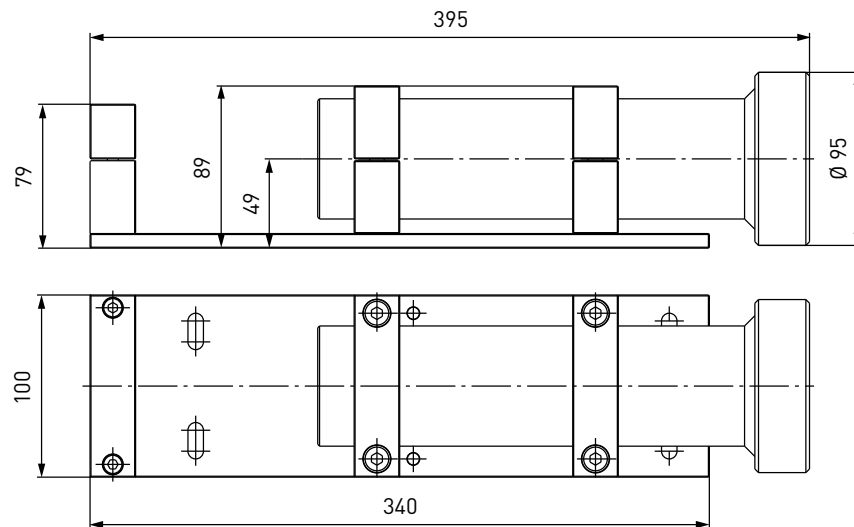

Part No.	Description
<b>C1-82110</b>	Dispenser mounting for TSA5 H <sub>2</sub>

## Accessories

### Filling and venting hoses

Suitable filling and venting hoses for the TSA5 H<sub>2</sub> breakaway coupling are available on request.

### Fittings

Stainless steel fittings for connecting port 'B2' to the filling hose resp. port 'C1' to the venting hose are available on request.

### Spare parts

Various parts are available as spares for the TSA5 H<sub>2</sub> breakaway coupling:

Part No.	Description
<b>W63194</b>	Receptacle insert for TSA5 H <sub>2</sub> with gas recirculation
<b>C1-119726</b>	Spare seal set for receptacle insert W63194
<b>E69-9062</b>	Wire filter insert 40 micron
<b>E69-46414</b>	Copper disc for G1/4" external thread (port C2)
<b>E69-45951</b>	Copper disc for G3/4" external thread (port B1)

## Other products

### OTHER PRODUCTS

You will find more products in our current catalogue no. 50



Further information on our homepage  
[www.weh.com](http://www.weh.com)

#### Abbreviations/Definition

Explanation of abbreviations see technical appendix in the catalogue or [www.weh.com](http://www.weh.com)

#### Safe product selection

Our WEH® Products are designed to be operated by qualified professional users (insofar as WEH® Products are also designed to be operated by other users in individual cases, this is explicitly stated in the corresponding operating instructions). You alone are responsible for the selection of WEH® Products and their configuration according to the requirements of your system. In doing so, please particularly consider your intended use, your performance data, your material compatibility, your system concept and your system limits as well as your technical and legal requirements for operation, handling and maintenance. The quality and safety of WEH® Products is our highest priority. For this reason, WEH® Products may not be used outside the specifications in the relevant Product data sheets and product descriptions. We also strongly recommend that you refrain from using third-party spare parts or a combination of WEH® Products with unsuitable third-party products. You alone are responsible for reviewing the suitability of third-party products. WEH® Products and WEH® Spare parts comply with our quality and safety standards.

#### Explanation on the Pressure Equipment Directive

These WEH® Products are generally and exclusively classified as pressure accessories for piping in accordance with Article 2 (5) of the Pressure Equipment Directive 2014/68/EU. These WEH® Products may not be used (i) as safety accessories or (ii) for vessels as defined by the Pressure Equipment Directive 2014/68/EU. Therefore, the application of these WEH® Products must comply with their classification as pressure accessories for piping. The assessment with regard to a different classification can, however, be made on request.

#### External change management

WEH reserves the right to update, optimise and adjust its products continuously. This may result in corresponding changes of the product. Customers will be informed proactively or unsolicited by WEH only in individual cases about product updates, product optimisations and/or product adaptations that have been carried out. You are free to contact WEH at any time to request information about any product updates, product optimisations and/or product adjustments.

© All rights reserved, WEH GmbH. Any unauthorized use is strictly forbidden. Subject to alteration.  
No liability will be assumed for any content. Herewith previous versions are no longer valid.

### » Contacting

For queries and further information, please do not hesitate to contact us.

Manufacturer:

**WEH GmbH Gas Technology**

Josef-Henle-Str. 1  
89257 Illertissen / Germany

Phone: +49 7303 95190-0  
Fax: +49 7303 95190-9999

Email: [h2sales@weh.com](mailto:h2sales@weh.com)  
[www.weh.com](http://www.weh.com)