

CHECK VALVES FOR GENERAL APPLICATIONS

# TVR200 of stainless steel

for use with liquid and gaseous media

## Features & benefits

- ▶ Stainless steel
- ▶ High leak tightness
- ▶ Valve seals are protected from media flow
- ▶ Wear and corrosion resistant
- ▶ Low-noise opening and closing
- ▶ Low cracking pressure
- ▶ Max. operating pressure up to 250 bar



## » Product family TVR200

### Description

The WEH® TVR200 Check valves made of stainless steel are ideal for applications with liquid and gaseous media up to max. 250 bar. The possible applications are just as varied as the design and the materials used.

The check valves are available in various connection configurations, such as double ferrule fittings, female and male threads and a nominal bore of up to 6 mm. For larger nominal bores the WEH® TVR2 Check valve is available.

Due to the high quality materials they are extremely wear-resistant, corrosion-resistant and durable. The check valves, which are very silent in use even under high flow rates, are characterized in particular by their very low cracking pressure and their optimum tightness which depends, among other things, on the setting of the cracking pressure.

The WEH® TVR200 are equipped with a ball seal. The internal seals are arranged so that they are protected from the media flow. This prevents damage to the seals from any dirt particles on the sealing components within the unit.

WEH® TVR200 Check valves are equipped with a FKM seal as standard. Other sealing materials are available on request. It is the customer's responsibility to clarify the media compatibility.

### Intended use

The WEH® TVR200 Check valves were only developed for reliable return flow prevention in a gaseous or liquid media flow. They are not designed to be used as filling or safety valves. The separation or shut off between different media or a medium and vacuum also does not represent a fundamental intended use.

If you have such an application or a similar application, please contact us!

The WEH® TVR200 Check valves are used in mechanical and plant engineering, chemical / pharmaceutical industry, conveyor technology, food industry, medical technology, etc.

### Sealing concept

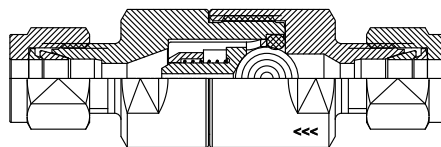

Ball seal construction

### Flow values

In the table below you will find the flow rates of the various nominal bores of our WEH® TVR200 Stainless steel check valves.

Nominal bore (DN)	Kv (Cv) value	Nominal bore (DN)	Kv (Cv) value
3 mm	0.17 (0.19)	4 mm	0.2 (0.2)
5 mm	0.4 (0.5)	6 mm	0.6 (0.7)

The flow curves were determined on the basis of the DIN/EN 60534-2 standard and refer to a cavitation-free flow (water). System-sided constrictions at the inlet and outlet can reduce the flow rate.

## » Product family TVR200

### Overview product series

Product series	Pressure range	Housing material	Connection types	Page
TVR200-S1	0 - 250 bar	Stainless steel	Double ferrule fitting Female thread Male thread	18

### Overview product series & connection configurations

Product series	Media inlet B1	Media outlet B2	Page
TVR200-S1-A01	Double ferrule fitting	Double ferrule fitting	20
TVR200-S1-A02	Female thread	Female thread	22
TVR200-S1-A03	Male thread	Male thread	24
TVR200-S1-A10	Double ferrule fitting	Female thread	25
TVR200-S1-A11	Double ferrule fitting	Male thread	26
TVR200-S1-A12	Female thread	Double ferrule fitting	27
TVR200-S1-A13	Female thread	Male thread	28
TVR200-S1-A14	Male thread	Double ferrule fitting	29
TVR200-S1-A15	Male thread	Female thread	30

## » Product series TVR200-S1 | 0 up to 250 bar

### Technical data

The following illustrations are examples of WEH® Check valves of the TVR200 product family.



Characteristics	Preferred variant space	Extended variant space
Product series	TVR200-S1	TVR200-S1
Connection configuration	A01, A02, A03	A01, A02, A03, A10, A11, A12, A13, A14, A15
Connection sizes for media inlet B1 / media outlet B2	<ul style="list-style-type: none"> <li>• Tube Ø 6 mm, Ø 8 mm, Ø 10 mm, Ø 12 mm</li> <li>• G1/8", G1/4"</li> <li>• NPT 1/8", NPT 1/4"</li> </ul>	<ul style="list-style-type: none"> <li>• Tube Ø 6 mm, Ø 8 mm, Ø 10 mm, Ø 12 mm</li> <li>• G1/8", G1/4"</li> <li>• NPT 1/8", NPT 1/4"</li> </ul>
Nominal bore (DN)	Acc. to design	Acc. to design
Max. allowable operating pressure PS	250 bar	250 bar
Cracking pressure PC*	<ul style="list-style-type: none"> <li>• 0.1 bar</li> <li>• 0.5 bar</li> </ul>	<ul style="list-style-type: none"> <li>• 0.1 bar</li> <li>• 0.2 bar</li> <li>• 0.5 bar</li> <li>• 1 bar</li> </ul>
Temperature range	-40 °C up to +200 °C	Depending on sealing material
Leak rate	$1 \times 10^{-4}$ mbar x l/s	$1 \times 10^{-4}$ mbar x l/s
Housing material	Stainless steel	Stainless steel
Spring material	Stainless steel	Stainless steel
Sealing material DW	FKM	<ul style="list-style-type: none"> <li>• FKM</li> <li>• EPDM</li> </ul>
Lubricant	Krytox® GPL 202	Krytox® GPL 202
Sealing concept	Ball sealing	Ball sealing
Flow direction	B1 → B2	B1 → B2

\* Please note that the cracking pressures may differ due to tolerances. The cracking pressure basically applies to the horizontal mounting of the check valve. For other mounting directions, the values can differ.

Other designs on request

## » Product series TVR200-S1 | 0 up to 250 bar

### Possible connection configurations

In addition to the table of technical characteristics (see page 18), the following possible connection configurations of WEH® Check valves of the TVR200 product family are listed. The connection configuration is part of the product series.

Connection configuration	Media inlet B1	Media outlet B2
A01	Double ferrule fitting	Double ferrule fitting
A02	Female thread	Female thread
A03	Male thread	Male thread
A10	Double ferrule fitting	Female thread
A11	Double ferrule fitting	Male thread
A12	Female thread	Double ferrule fitting
A13	Female thread	Male thread
A14	Male thread	Double ferrule fitting
A15	Male thread	Female thread

## » Product series TVR200-S1 | 0 up to 250 bar

### Ordering | TVR200-S1-A01 - double ferrule fitting on both sides

Inlet B1: double ferrule fitting / outlet B2: double ferrule fitting

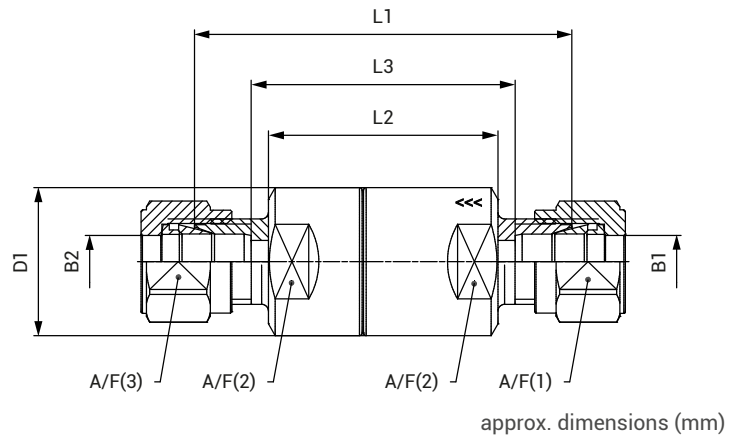

### B1 / B2: double ferrule fitting

Connection size: media inlet B1 = media outlet B2

Check valves of the preferred variant space:

Part No.	B1	B2	DN	PC (bar)	DW	L1	L2	L3	D1	A/F(1) / A/F(3)	A/F(2)	AVL*
C1-170000	Ø 6	Ø 6	5	0.1	FKM	56	34	40	22	14	19	RM
C1-170041	Ø 6	Ø 6	5	0.5	FKM	56	34	40	22	14	19	AH
C1-170043	Ø 8	Ø 8	6	0.1	FKM	57	33	40	22	16	19	RM
C1-170046	Ø 8	Ø 8	6	0.5	FKM	57	33	40	22	16	19	RM
C1-170054	Ø 10	Ø 10	6	0.1	FKM	57	33	38	22	19	19	RM
C1-170055	Ø 10	Ø 10	6	0.5	FKM	57	33	38	22	19	19	AH
C1-170053	Ø 12	Ø 12	6	0.1	FKM	57	33	32	22	22	19	RM
C1-170058	Ø 12	Ø 12	6	0.5	FKM	57	33	32	22	22	19	AH

\* AVL: availability see page 12

## » Product series TVR200-S1 | 0 up to 250 bar

Connection size: media inlet B1 = media outlet B2 resp.  
media inlet B1 ≠ media outlet B2

### Configurable check valves of the extended variant space:

Below you will find possible examples of TVR200 check valves in the extended variant space. This offers further configuration options (connection configuration, connection size, cracking pressure, sealing material) beyond the preferred variant space.

Part No.	B1	B2	DN	PC (bar)	DW	L1	L2	L3	D1	A/F(1)	A/F(2)	A/F(3)	AVL*
On request	∅ 6	∅ 6	5	0.1	EPDM					On request			AH
On request	∅ 8	∅ 8	6	1.0	FKM					On request			AH
On request	∅ 10	∅ 10	6	0.2	EPDM					On request			AH
On request	∅ 8	∅ 10	6	0.1	FKM					On request			AH
On request	∅ 10	∅ 8	6	0.5	EPDM					On request			AH
On request	∅ 12	∅ 10	6	0.2	EPDM					On request			AH

\* AVL: availability see page 12

Further designs that do not correspond to the extended variant space can be requested individually. Please refer to *chapter 1.9 Information on your request*. Please note that the availability for individual, customer-specific check valves may vary.



## » Product series TVR200-S1 | 0 up to 250 bar

### Ordering | TVR200-S1-A02 - female thread on both sides

Inlet B1: female thread / outlet B2: female thread

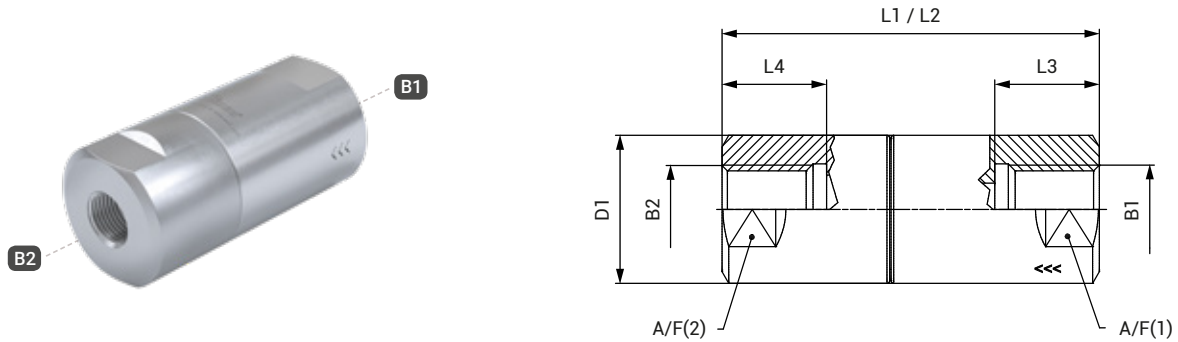

approx. dimensions (mm)

#### B1 / B2: Whitworth tube thread acc. to DIN EN ISO 228-1

Connection size: media inlet B1 = media outlet B2

#### Check valves of the preferred variant space:

Part No.	B1	B2	DN	PC (bar)	DW	L1 / L2	L3 / L4	D1	A/F(1) / A/F(2)	AVL*
C1-170066	G1/8"	G1/8"	6	0.1	FKM	56	10	22	19	RM
C1-170065	G1/8"	G1/8"	6	0.5	FKM	56	10	22	19	AH
C1-165315	G1/4"	G1/4"	6	0.1	FKM	56	16	22	19	RM
C1-170062	G1/4"	G1/4"	6	0.5	FKM	56	16	22	19	RM

\* AVL: availability see page 12

Connection size: media inlet B1 = media outlet B2 resp.  
media inlet B1 ≠ media outlet B2

#### Configurable check valves of the extended variant space:

Below you will find possible examples of TVR200 check valves in the extended variant space. This offers further configuration options (connection configuration, connection size, cracking pressure, sealing material) beyond the preferred variant space.

Part No.	B1	B2	DN	PC (bar)	DW	L1	L2	L3	L4	D1	A/F(1)	A/F(2)	AVL*
On request	G1/8"	G1/8"	6	0.1	EPDM					On request			AH
On request	G1/4"	G1/4"	6	0.2	EPDM					On request			AH
On request	G1/8"	G1/4"	6	1.0	FKM					On request			AH
On request	G1/4"	G1/8"	6	0.2	EPDM					On request			AH

\* AVL: availability see page 12

Further designs that do not correspond to the extended variant space can be requested individually. Please refer to *chapter 1.9 Information on your request*. Please note that the availability for individual, customer-specific check valves may vary.

## » Product series TVR200-S1 | 0 up to 250 bar

### B1 / B2: NPT thread (ANSI B 1.20.1-1983 (R1992))

Connection size: media inlet B1 = media outlet B2

#### Check valves of the preferred variant space:

Part No.	B1	B2	DN	PC (bar)	DW	L1 / L2	L3 / L4	D1	A/F(1) / A/F(2)	AVL*
<b>C1-169134</b>	NPT 1/8"	NPT 1/8"	6	0.1	FKM	56	7	22	19	**
<b>C1-170249</b>	NPT 1/8"	NPT 1/8"	6	0.5	FKM	56	7	22	19	**
<b>C1-169135</b>	NPT 1/4"	NPT 1/4"	6	0.1	FKM	56	10	22	19	**
<b>C1-170252</b>	NPT 1/4"	NPT 1/4"	6	0.5	FKM	56	10	22	19	**

\* AVL: availability see page 12

\*\* Availability on request

Connection size: media inlet B1 = media outlet B2 resp.  
media inlet B1 ≠ media outlet B2

#### Configurable check valves of the extended variant space:

Below you will find possible examples of TVR200 check valves in the extended variant space. This offers further configuration options (connection configuration, connection size, cracking pressure, sealing material) beyond the preferred variant space.

Part No.	B1	B2	DN	PC (bar)	DW	L1	L2	L3	L4	D1	A/F(1)	A/F(2)	AVL*
<b>On request</b>	NPT 1/8"	NPT 1/8"	6	0.1	EPDM	On request						**	
<b>On request</b>	NPT 1/4"	NPT 1/4"	6	0.2	EPDM	On request						**	
<b>On request</b>	NPT 1/8"	NPT 1/4"	6	1.0	FKM	On request						**	
<b>On request</b>	NPT 1/4"	NPT 1/8"	6	0.2	EPDM	On request						**	

\* AVL: availability see page 12

\*\* Availability on request

Further designs that do not correspond to the extended variant space can be requested individually. Please refer to *chapter 1.9 Information on your request*. Please note that the availability for individual, customer-specific check valves may vary.

## » Product series TVR200-S1 | 0 up to 250 bar

### Ordering | TVR200-S1-A03 - male thread on both sides

Inlet B1: male thread / outlet B2: male thread

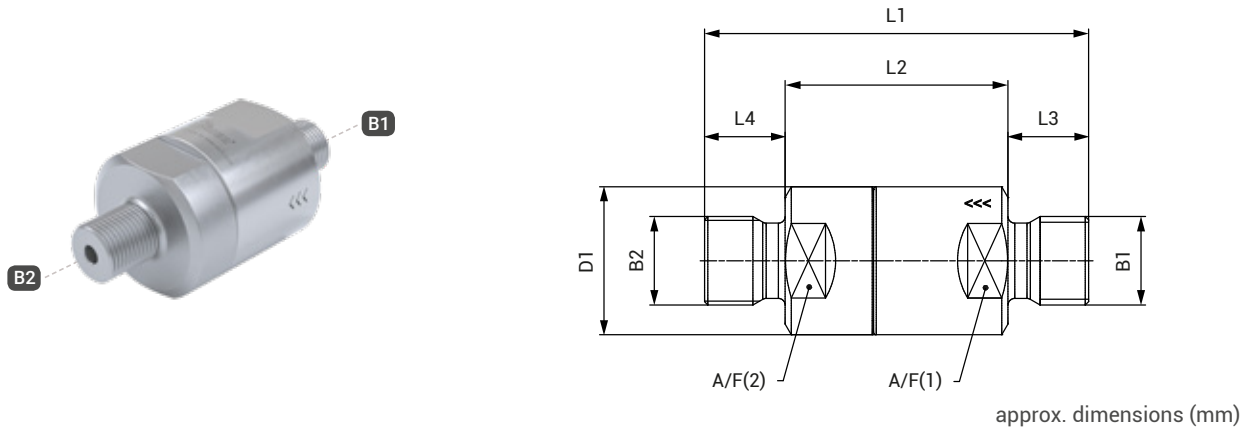

#### B1 / B2: Whitworth tube thread acc. to DIN EN ISO 228-1

Connection size: media inlet B1 = media outlet B2

#### Check valves of the preferred variant space:

Part No.	B1	B2	DN	PC (bar)	DW	L1	L2	L3 / L4	D1	A/F(1) / A/F(2)	AVL*
C1-170078	G1/8"	G1/8"	4	0.1	FKM	56	40	8	22	19	RM
C1-170079	G1/8"	G1/8"	4	0.5	FKM	56	40	8	22	19	AH
C1-170085	G1/4"	G1/4"	6	0.1	FKM	57	33	12	22	19	RM
C1-170086	G1/4"	G1/4"	6	0.5	FKM	57	33	12	22	19	AH

\* AVL: availability see page 12

Connection size: media inlet B1 = media outlet B2 resp.  
media inlet B1 ≠ media outlet B2

#### Configurable check valves of the extended variant space:

Below you will find possible examples of TVR200 check valves in the extended variant space. This offers further configuration options (connection configuration, connection size, cracking pressure, sealing material) beyond the preferred variant space.

Part No.	B1	B2	DN	PC (bar)	DW	L1	L2	L3	L4	D1	A/F(1)	A/F(2)	AVL*
On request	G1/8"	G1/8"	4	0.1	EPDM					On request			AH
On request	G1/4"	G1/4"	5	0.2	EPDM					On request			AH
On request	G1/8"	G1/4"	4	1.0	FKM					On request			AH
On request	G1/4"	G1/8"	4	0.2	EPDM					On request			AH

\* AVL: availability see page 12

Further designs that do not correspond to the extended variant space can be requested individually.

Please refer to *chapter 1.9 Information on your request*.

Please note that the availability for individual, customer-specific check valves may vary.

## » Product series TVR200-S1 | 0 up to 250 bar

### Ordering | TVR200-S1-A10 - double ferrule fitting / female thread

Inlet B1: double ferrule fitting / outlet B2: female thread

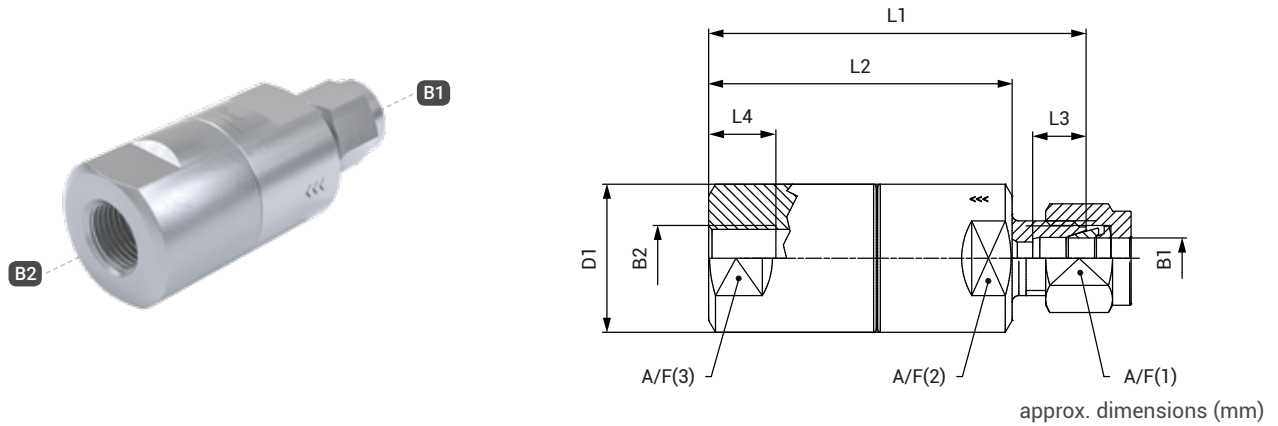

**B1 = double ferrule fitting / B2 = Whitworth tube thread acc. to DIN EN ISO 228-1**

Connection size: media inlet B1 ≠ media outlet B2

#### Configurable check valves of the extended variant space:

Below you will find possible examples of TVR200 check valves in the extended variant space. This offers further configuration options (connection configuration, connection size, cracking pressure, sealing material) beyond the preferred variant space.

Part No.	B1	B2	DN	PC (bar)	DW	L1	L2	L3	L4	D1	A/F(1)	A/F(2)	AVL*
On request	∅ 6	G1/8"	5	0.1	FKM					On request			AH
On request	∅ 8	G1/4"	5	0.5	FKM					On request			AH
On request	∅ 10	G1/8"	6	0.1	FKM					On request			AH
On request	∅ 6	G1/4"	5	0.5	EPDM					On request			AH
On request	∅ 8	G1/8"	6	1.0	FKM					On request			AH
On request	∅ 10	G1/4"	6	0.2	EPDM					On request			AH

\* AVL: availability see page 12

Further designs that do not correspond to the extended variant space can be requested individually.

Please refer to *chapter 1.9 Information on your request*.

Please note that the availability for individual, customer-specific check valves may vary.

## » Product series TVR200-S1 | 0 up to 250 bar

### Ordering | TVR200-S1-A11 - double ferrule fitting / male thread

Inlet B1: double ferrule fitting / outlet B2: male thread

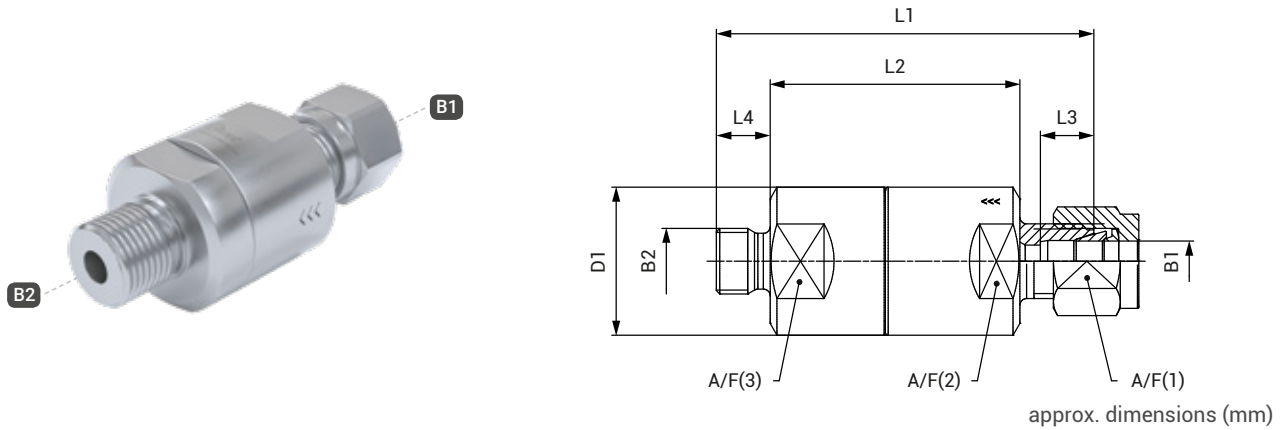

#### B1: double ferrule fitting / B2: Whitworth tube thread acc. to DIN EN ISO 228-1

Connection size: media inlet B1 ≠ media outlet B2

#### Configurable check valves of the extended variant space:

Below you will find possible examples of TVR200 check valves in the extended variant space. This offers further configuration options (connection configuration, connection size, cracking pressure, sealing material) beyond the preferred variant space.

Part No.	B1	B2	DN	PC (bar)	DW	L1	L2	L3	L4	D1	A/F(1)	A/F(2)	AVL*
On request	∅ 6	G1/8"	5	0.1	FKM					On request			AH
On request	∅ 8	G1/4"	5	0.5	FKM					On request			AH
On request	∅ 10	G1/8"	6	0.1	FKM					On request			AH
On request	∅ 6	G1/4"	5	0.5	EPDM					On request			AH
On request	∅ 8	G1/8"	6	1.0	FKM					On request			AH
On request	∅ 10	G1/4"	6	0.2	EPDM					On request			AH

\* AVL: availability see page 12

Further designs that do not correspond to the extended variant space can be requested individually.

Please refer to *chapter 1.9 Information on your request*.

Please note that the availability for individual, customer-specific check valves may vary.

## » Product series TVR200-S1 | 0 up to 250 bar

### Ordering | TVR200-S1-A12 - female thread / double ferrule fitting

Inlet B1: female thread / outlet B2: double ferrule fitting

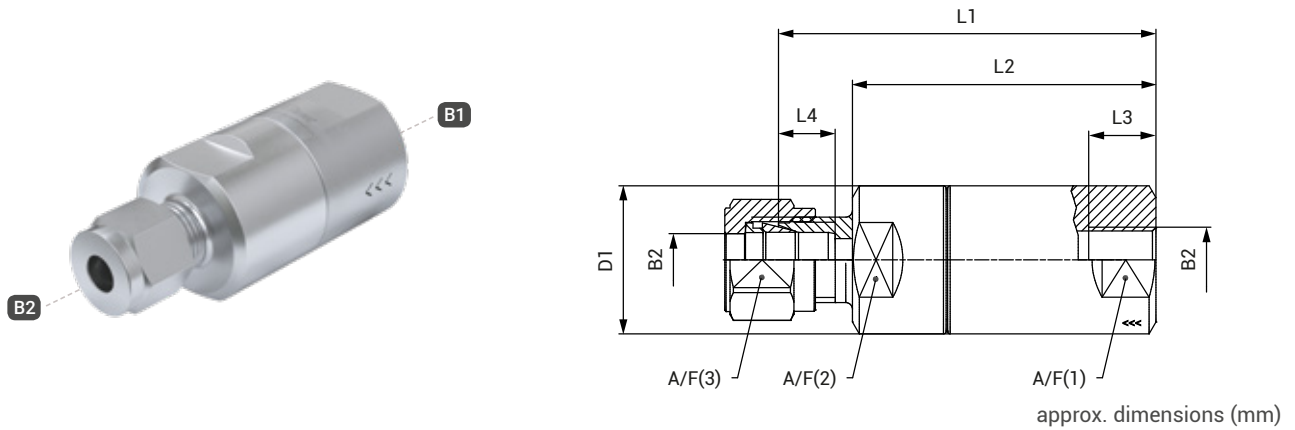

#### B1: Whitworth tube thread acc. to DIN EN ISO 228-1 / B2: double ferrule fitting

Connection size: media inlet B1 ≠ media outlet B2

#### Configurable check valves of the extended variant space:

Below you will find possible examples of TVR200 check valves in the extended variant space. This offers further configuration options (connection configuration, connection size, cracking pressure, sealing material) beyond the preferred variant space.

Part No.	B1	B2	DN	PC (bar)	DW	L1	L2	L3	L4	D1	A/F(1)	A/F(2)	AVL*
On request	G1/8"	Ø 8	6	0.1	FKM					On request			AH
On request	G1/4"	Ø 10	6	0.5	FKM					On request			AH
On request	G1/8"	Ø 12	6	0.1	FKM					On request			AH
On request	G1/4"	Ø 8	6	0.5	EPDM					On request			AH
On request	G1/8"	Ø 10	6	1.0	FKM					On request			AH
On request	G1/4"	Ø 12	6	0.2	EPDM					On request			AH

\* AVL: availability see page 12

Further designs that do not correspond to the extended variant space can be requested individually.

Please refer to *chapter 1.9 Information on your request*.

Please note that the availability for individual, customer-specific check valves may vary.

## » Product series TVR200-S1 | 0 up to 250 bar

### Ordering | TVR200-S1-A13 - female thread / male thread

Inlet B1: female thread / outlet B2: male thread

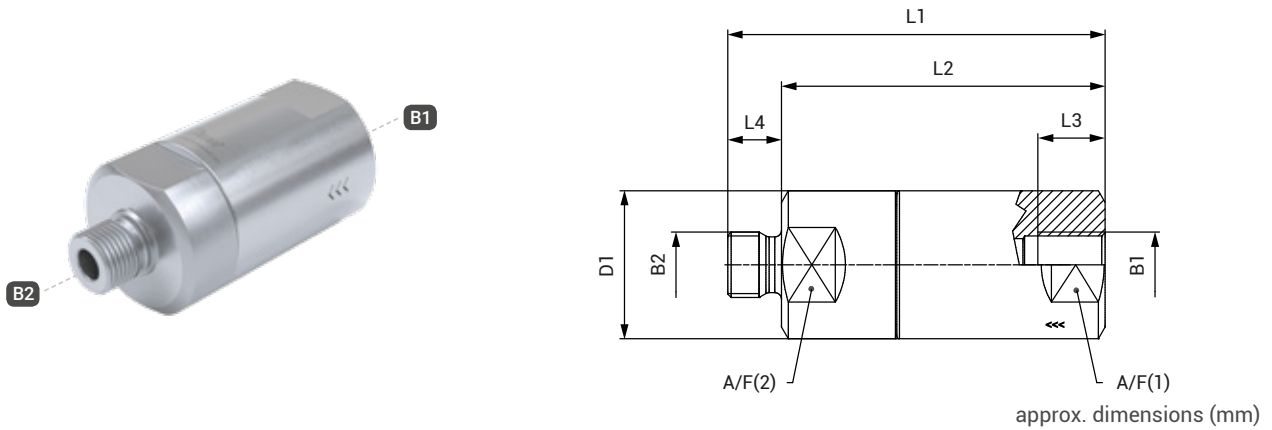

#### B1 / B2: Whitworth tube thread acc. to DIN EN ISO 228-1

Connection size: media inlet B1 = media outlet B2 resp.  
media inlet B1 ≠ media outlet B2

#### Configurable check valves of the extended variant space:

Below you will find possible examples of TVR200 check valves in the extended variant space. This offers further configuration options (connection configuration, connection size, cracking pressure, sealing material) beyond the preferred variant space.

Part No.	B1	B2	DN	PC (bar)	DW	L1	L2	L3	L4	D1	A/F(1)	A/F(2)	AVL*
On request	G1/8"	G1/8"	3	0.1	FKM					On request			AH
On request	G1/4"	G1/4"	5	0.5	FKM					On request			AH
On request	G1/8"	G1/8"	3	0.1	EPDM					On request			AH
On request	G1/4"	G1/4"	5	0.2	EPDM					On request			AH
On request	G1/8"	G1/4"	5	1.0	FKM					On request			AH
On request	G1/4"	G1/8"	5	0.2	EPDM					On request			AH

\* AVL: availability see page 12

Further designs that do not correspond to the extended variant space can be requested individually.

Please refer to *chapter 1.9 Information on your request*.

Please note that the availability for individual, customer-specific check valves may vary.

## » Product series TVR200-S1 | 0 up to 250 bar

### Ordering | TVR200-S1-A14 - male thread / double ferrule fitting

inlet B1: male thread / outlet B2: double ferrule fitting

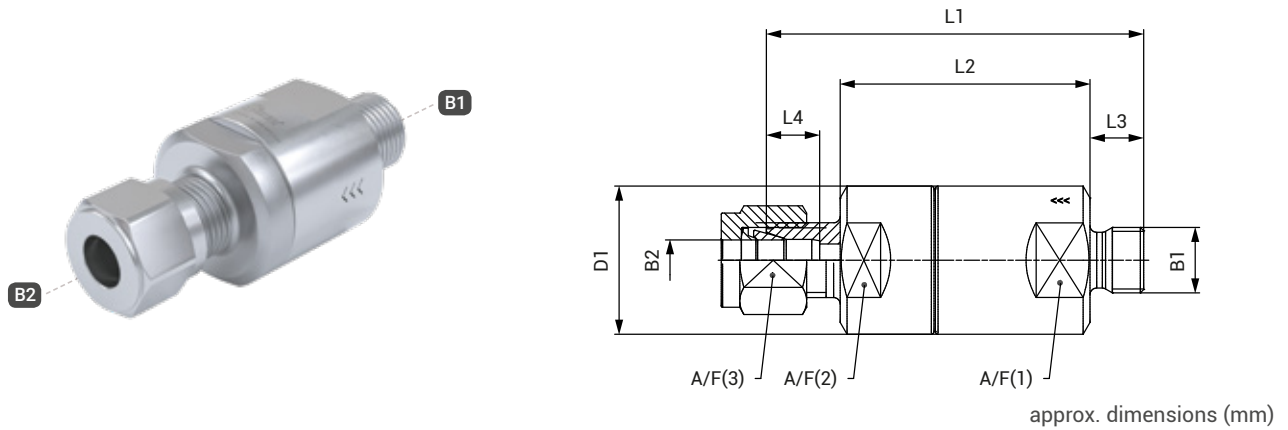

#### B1: Whitworth tube thread acc. to DIN EN ISO 228-1 / B2: double ferrule fitting

Connection size: media inlet B1 ≠ media outlet B2

#### Configurable check valves of the extended variant space:

Below you will find possible examples of TVR200 check valves in the extended variant space. This offers further configuration options (connection configuration, connection size, cracking pressure, sealing material) beyond the preferred variant space.

Part No.	B1	B2	DN	PC (bar)	DW	L1	L2	L3	L4	D1	A/F(1)	A/F(2)	AVL*
On request	G1/8"	∅ 6	3	0.1	FKM					On request			AH
On request	G1/4"	∅ 8	5	0.5	FKM					On request			AH
On request	G1/8"	∅ 10	3	0.1	FKM					On request			AH
On request	G1/4"	∅ 12	5	0.1	FKM					On request			AH
On request	G1/8"	∅ 8	3	0.5	EPDM					On request			AH
On request	G1/4"	∅ 6	5	0.2	FKM					On request			AH
On request	G1/8"	∅ 10	3	1.0	FKM					On request			AH
On request	G1/4"	∅ 10	5	0.2	EPDM					On request			AH

\* AVL: availability see page 12

Further designs that do not correspond to the extended variant space can be requested individually.

Please refer to *chapter 1.9 Information on your request*.

Please note that the availability for individual, customer-specific check valves may vary.



## » Product series TVR200-S1 | 0 up to 250 bar

### Ordering | TVR200-S1-A15 - male thread / female thread

Inlet B1: male thread / outlet B2: female thread

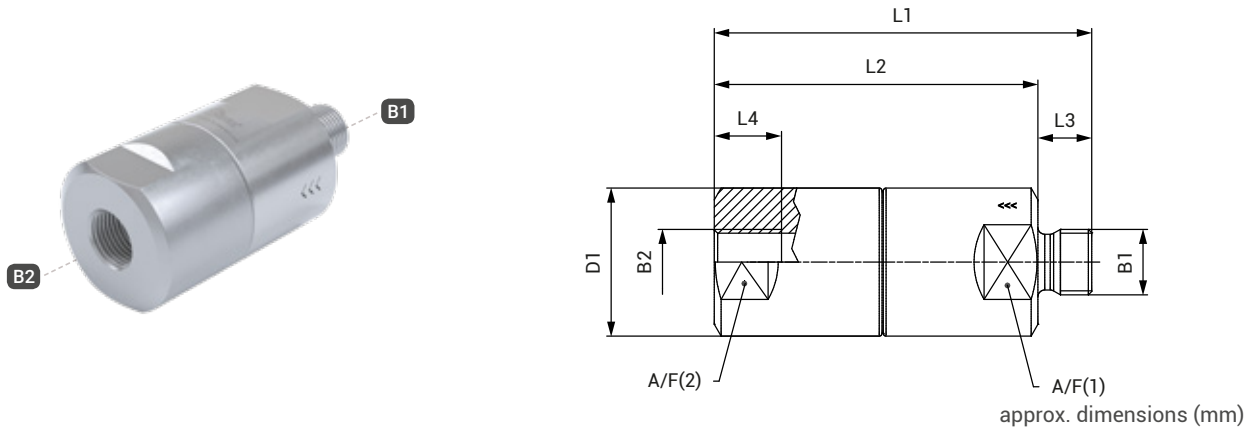

#### B1 / B2: Whitworth tube thread acc. to DIN EN ISO 228-1

Connection size: media inlet B1 = media outlet B2 resp.  
media inlet B1 ≠ media outlet B2

#### Configurable check valves of the extended variant space:

Below you will find possible examples of TVR200 check valves in the extended variant space. This offers further configuration options (connection configuration, connection size, cracking pressure, sealing material) beyond the preferred variant space.

Part No.	B1	B2	DN	PC (bar)	DW	L1	L2	L3	L4	D1	A/F(1)	A/F(2)	AVL*
On request	G1/8"	G1/8"	3	0.1	FKM					On request			AH
On request	G1/4"	G1/4"	5	0.5	FKM					On request			AH
On request	G1/8"	G1/8"	3	0.1	EPDM					On request			AH
On request	G1/4"	G1/4"	5	0.2	EPDM					On request			AH
On request	G1/8"	G1/4"	5	1.0	FKM					On request			AH
On request	G1/4"	G1/8"	5	0.2	EPDM					On request			AH

\* AVL: availability see page 12

Further designs that do not correspond to the extended variant space can be requested individually.

Please refer to *chapter 1.9 Information on your request*.

Please note that the availability for individual, customer-specific check valves may vary.