

# Type **TVR5 H<sub>2</sub>** WEH<sup>®</sup> Check Valve

for buses, trucks and fuelling stations



## General

### DESCRIPTION



#### Features

- Robust construction
- Low-noise opening and closing
- Corrosion resistant stainless steel
- High leak tightness

The WEH<sup>®</sup> TVR5 H<sub>2</sub> is the largest of our check valves. It is most efficient and developed specifically for H<sub>2</sub> buses and trucks. The check valve system is designed to minimize the effect of dirt particles on the sealing components within the unit. The WEH<sup>®</sup> TVR5 H<sub>2</sub> Check Valve is constructed of corrosion-resistant stainless steel achieving a very durable unit due to its robust internal structure.

#### Application

Check valve for buses and trucks, also suitable for installation in fuelling stations.

### TECHNICAL DATA

Characteristic	Basic version	Options
Nominal bore DN	Max. 14 mm, depending on design	On request
Pressure range	PN = 350 bar (5,000 psi)   PS = 450 bar   PT = 675 bar	
Temperature range	-40 °C up to +85 °C (-40 °F up to +185 °F)	On request
Material	Corrosion resistant stainless steel	On request
Sealing material	Hydrogen compatible	On request
Design	Incl. fittings (only for check valves with tube fitting)	On request

**Ordering**

**ORDERING** | WEH® TVR5 H<sub>2</sub> Check Valve with tube fitting on both sides

approx. dimensions (mm)

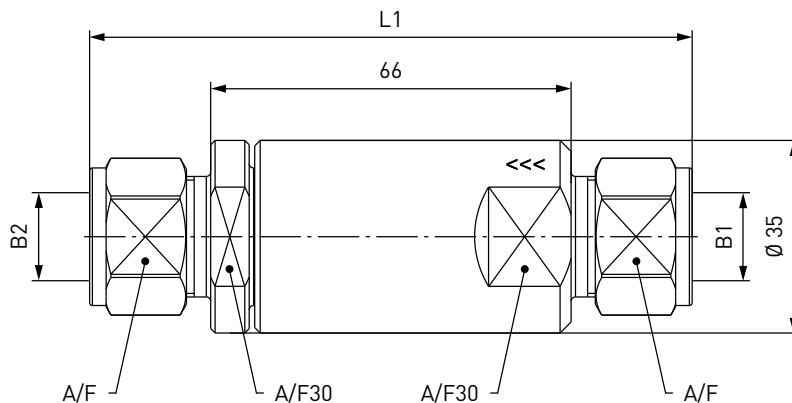

Part No.	Description	DN	Pressure (PN)	Inlet B1	Outlet B2	L1	A/F
<b>C1-30216-X1-X01</b>	TVR5 H <sub>2</sub>	11	350 bar / 5,000 psi	Tube Ø 12*	Tube Ø 12*	110	22
<b>C1-30215-X1-X01</b>	TVR5 H <sub>2</sub>	14	350 bar / 5,000 psi	Tube Ø 16*	Tube Ø 16*	111	25

\* double ferrule fitting

**ORDERING** | WEH® TVR5 H<sub>2</sub> Check Valve with internal thread on both sides

approx. dimensions (mm)

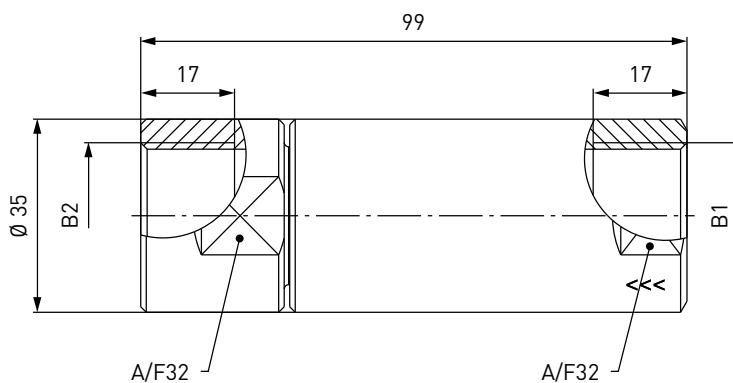

Part No.	Description	DN	Pressure (PN)	Inlet B1 (internal thread)	Outlet B2 (internal thread)
<b>C1-43326-X1-X01</b>	TVR5 H <sub>2</sub>	12	350 bar / 5,000 psi	G3/4"*	G3/4"*

\* acc. to DIN 3852-2

Other connection sizes and versions on request.

## Other products

### OTHER PRODUCTS

You will find more products in our current catalogue no. 50



Further information on our homepage  
[www.weh.com](http://www.weh.com)

#### Abbreviations/Definition

Explanation of abbreviations see technical appendix in the catalogue or [www.weh.com](http://www.weh.com)

#### Safe product selection

Our WEH® Products are designed to be operated by qualified professional users (insofar as WEH® Products are also designed to be operated by other users in individual cases, this is explicitly stated in the corresponding operating instructions). You alone are responsible for the selection of WEH® Products and their configuration according to the requirements of your system. In doing so, please particularly consider your intended use, your performance data, your material compatibility, your system concept and your system limits as well as your technical and legal requirements for operation, handling and maintenance. The quality and safety of WEH® Products is our highest priority. For this reason, WEH® Products may not be used outside the specifications in the relevant Product data sheets and product descriptions. We also strongly recommend that you refrain from using third-party spare parts or a combination of WEH® Products with unsuitable third-party products. You alone are responsible for reviewing the suitability of third-party products. WEH® Products and WEH® Spare parts comply with our quality and safety standards.

#### Explanation on the Pressure Equipment Directive

These WEH® Products are generally and exclusively classified as pressure accessories for piping in accordance with Article 2 (5) of the Pressure Equipment Directive 2014/68/EU. These WEH® Products may not be used (i) as safety accessories or (ii) for vessels as defined by the Pressure Equipment Directive 2014/68/EU. Therefore, the application of these WEH® Products must comply with their classification as pressure accessories for piping. The assessment with regard to a different classification can, however, be made on request.

#### External change management

WEH reserves the right to update, optimise and adjust its products continuously. This may result in corresponding changes of the product. Customers will be informed proactively or unsolicited by WEH only in individual cases about product updates, product optimisations and/or product adaptations that have been carried out. You are free to contact WEH at any time to request information about any product updates, product optimisations and/or product adjustments.

© All rights reserved, WEH GmbH. Any unauthorized use is strictly forbidden. Subject to alteration.  
No liability will be assumed for any content. Herewith previous versions are no longer valid.

### » Contacting

For queries and further information, please do not hesitate to contact us.

Manufacturer:

**WEH GmbH Gas Technology**

Josef-Henle-Str. 1  
89257 Illertissen / Germany

Phone: +49 7303 95190-0  
Fax: +49 7303 95190-9999

Email: [h2sales@weh.com](mailto:h2sales@weh.com)  
[www.weh.com](http://www.weh.com)