

# Type **TVR1 H<sub>2</sub> 70 MPa**

**WEH<sup>®</sup> Check Valve**

for cars and fuelling stations



## General

### DESCRIPTION



#### Features

- Robust construction
- Low-noise opening and closing
- Corrosion resistant stainless steel
- High leak tightness

With the TVR1 H<sub>2</sub> 70 MPa WEH offers a high performance check valve for use with hydrogen cars or fuelling stations of the latest generation. The check valve system is designed to minimize the effect of dirt particles on the sealing components within the unit. The WEH® TVR1 H<sub>2</sub> 70 MPa Check Valve is constructed of corrosion-resistant stainless steel achieving a very durable unit due to its robust internal structure.

#### Application

Check valve for cars (e1 approval), also suitable for installation in fuelling stations.

### TECHNICAL DATA

Characteristic	Basic version	Options
Nominal bore DN	Max. 4 mm, depending on design	On request
Pressure range	PN = 700 bar (10,000 psi)   PS = 875 bar   PT = 1255 bar	
Temperature range	-40 °C up to +85 °C (-40 °F up to +185 °F)	On request
Material	Corrosion resistant stainless steel	On request
Sealing material	Hydrogen compatible	On request
Design	With resp. without integrated particle filter (20 micron) and incl. fittings (only for check valves with tube fitting)	On request
Registration	e1 00 0009 (Regulation (EC) No. 79/2009)	

**Ordering**

**ORDERING** | WEH® TVR1 H<sub>2</sub> 70 MPa Check Valve with external thread on both sides (Face Seal at the inlet)  
approx. dimensions (mm)

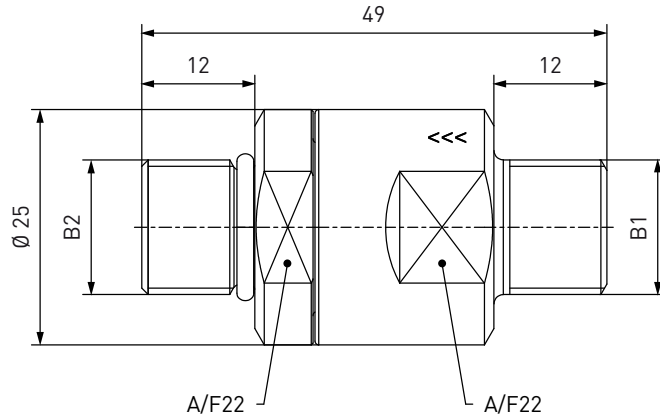

Part No.	Description	DN	Pressure (PN)	Inlet B1 (external thread)	Outlet B2 (external thread)
<b>C1-117366</b>	TVR1 H <sub>2</sub> 70 MPa (e1)	4	700 bar / 10,000 psi	UNF 9/16"-18 for sealing with O-Lok® Face Seal** for tube Ø 6 (1/4")	UNF 9/16"-18*

\* acc. to SAE J1926

\*\* Face Seal acc. to SAE J1453

**ORDERING** | WEH® TVR1 H<sub>2</sub> 70 MPa Check Valve with external thread on both sides (Face Seal at the outlet)  
approx. dimensions (mm)

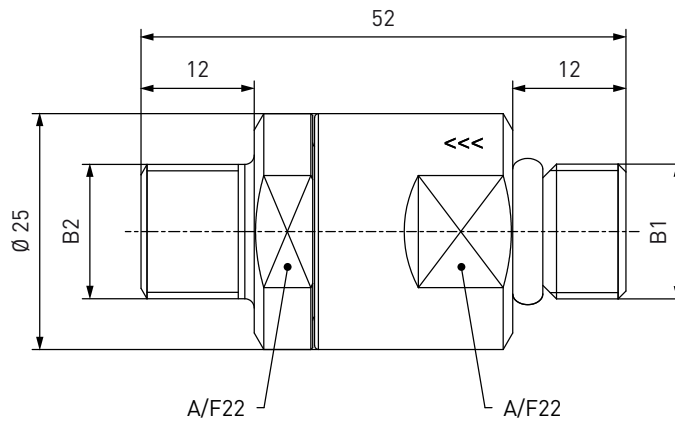

Part No.	Description	DN	Pressure (PN)	Inlet B1 (external thread)	Outlet B2 (external thread)
<b>C1-76958</b>	TVR1 H <sub>2</sub> 70 MPa (e1)	4	700 bar / 10,000 psi	UNF 9/16"-18*	UNF 9/16"-18 for sealing with O-Lok® Face Seal** for tube Ø 6 (1/4")

\* acc. to SAE J1926

\*\* Face Seal acc. to SAE J1453

**Ordering**

**ORDERING** | WEH® TVR1 H<sub>2</sub> 70 MPa Check Valve with external thread on both sides (Face Seal on both sides)  
approx. dimensions (mm)

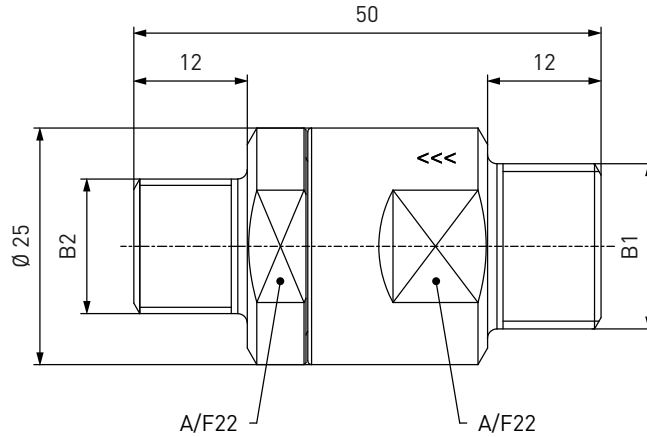

Part No.	Description	DN	Pressure (PN)	Inlet B1 (external thread)	Outlet B2 (external thread)
<b>C1-76959</b>	TVR1 H <sub>2</sub> 70 MPa (e1)	4	700 bar / 10,000 psi	UN 11/16"-16 for sealing with O-Lok® Face Seal* for tube Ø 10 (3/8")	UNF 9/16"-18 for sealing with O-Lok® Face Seal* for tube Ø 6 (1/4")

\* Face Seal acc. to SAE J1453

**ORDERING** | WEH® TVR1 H<sub>2</sub> 70 MPa Check Valve with internal / external thread and filter (20 micron)  
approx. dimensions (mm)

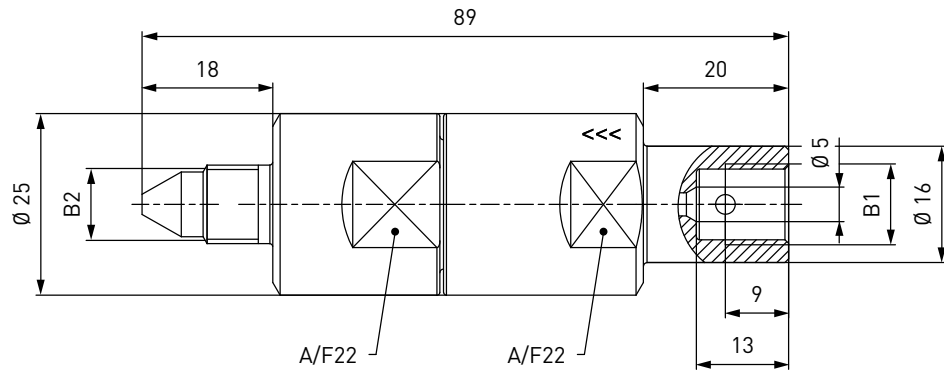

Part No.	Description	DN	Pressure (PN)	Inlet B1 (internal thread)	Outlet B2 (external thread)
<b>C1-87743</b>	TVR1 H <sub>2</sub> 70 MPa (e1)	2.5	700 bar / 10,000 psi	UNF 7/16"-20*	UNF 7/16"-20**

\* 60° cone, MP-fitting  
\*\* 59° cone, MP-fitting

Other connection sizes and versions on request.

## Other products

### OTHER PRODUCTS

You will find more products in our current catalogue no. 50



Further information on our homepage  
[www.weh.com](http://www.weh.com)

#### Abbreviations/Definition

Explanation of abbreviations see technical appendix in the catalogue or [www.weh.com](http://www.weh.com)

#### Safe product selection

Our WEH® Products are designed to be operated by qualified professional users (insofar as WEH® Products are also designed to be operated by other users in individual cases, this is explicitly stated in the corresponding operating instructions). You alone are responsible for the selection of WEH® Products and their configuration according to the requirements of your system. In doing so, please particularly consider your intended use, your performance data, your material compatibility, your system concept and your system limits as well as your technical and legal requirements for operation, handling and maintenance. The quality and safety of WEH® Products is our highest priority. For this reason, WEH® Products may not be used outside the specifications in the relevant Product data sheets and product descriptions. We also strongly recommend that you refrain from using third-party spare parts or a combination of WEH® Products with unsuitable third-party products. You alone are responsible for reviewing the suitability of third-party products. WEH® Products and WEH® Spare parts comply with our quality and safety standards.

#### Explanation on the Pressure Equipment Directive

These WEH® Products are generally and exclusively classified as pressure accessories for piping in accordance with Article 2 (5) of the Pressure Equipment Directive 2014/68/EU. These WEH® Products may not be used (i) as safety accessories or (ii) for vessels as defined by the Pressure Equipment Directive 2014/68/EU. Therefore, the application of these WEH® Products must comply with their classification as pressure accessories for piping. The assessment with regard to a different classification can, however, be made on request.

#### External change management

WEH reserves the right to update, optimise and adjust its products continuously. This may result in corresponding changes of the product. Customers will be informed proactively or unsolicited by WEH only in individual cases about product updates, product optimisations and/or product adaptations that have been carried out. You are free to contact WEH at any time to request information about any product updates, product optimisations and/or product adjustments.

© All rights reserved, WEH GmbH. Any unauthorized use is strictly forbidden. Subject to alteration.  
No liability will be assumed for any content. Herewith previous versions are no longer valid.

### » Contacting

For queries and further information, please do not hesitate to contact us.

Manufacturer:

**WEH GmbH Gas Technology**

Josef-Henle-Str. 1  
89257 Illertissen / Germany

Phone: +49 7303 95190-0  
Fax: +49 7303 95190-9999

Email: [h2sales@weh.com](mailto:h2sales@weh.com)  
[www.weh.com](http://www.weh.com)