



2019

WEH[®] Connectors

for the Breathing Air Industry

Connection solutions for BA laboratories and fire brigades

Catalogue 60 | V1.0



© All rights reserved, WEH GmbH.

Unauthorized copies are strictly forbidden as well as the publishing and using without the written consent of the WEH company. By the transfer of an up to date brochure or document all precursory versions will run out of validity. As a matter of principle the latest up to date version of brochures and other documents are valid. These versions can be inquired by the WEH company. Our general terms and conditions and the agreement on protection of know-how and quality assurance (www.weh.com) are valid for consignments and all other services, unless otherwise agreed. We do not accept general terms and conditions of the purchaser.

WEH® is a registered trademark of the WEH GmbH.

» Table of contents

1 Breathing air products	4
1.1 Overview	4
2 CLICKMATE® TW154 Upgrading existing filling rigs	6
2.1 General	6
2.2 Ordering	8
3 CLICKMATE® TW154 Direct connection to hose filling systems	10
3.1 General	10
3.2 Ordering	12
4 CLICKMATE® TW154 Filling twin cylinder packs	14
4.1 General	14
4.2 Ordering	16
5 CLICKMATE® Versions	18
5.1 Overview	18
6 WEH® Connector TW156 For respiratory protective equipment	20
6.1 General	20
6.2 Ordering	22
7 Further information	24
7.1 Technical appendix	24
7.2 Brochure data	27

» WEH[®] Connectors for breathing air

SETTING NEW STANDARDS FOR BA FILLING

Since 1980 WEH has offered an innovative range of quick connectors for pressure and function testing that achieves a connection in seconds. Included in the vast product range are WEH[®] Connectors for filling BA cylinders and for testing respiratory protective equipment.

Satisfied customers range from manufacturers of filling rigs to fire brigades and BA laboratories.

CLICKMATE[®] FOR CONVERSION OF EXISTING FILLING RIGS AND UPGRADING HOSE FILLING SYSTEMS

Breathing air (BA) cylinders can now be filled quickly and easily using WEH[®] Conversion kits fitted to existing installations.

The **CLICKMATE[®] TW154** grips directly into the thread of the cylinder valve thus eliminating strenuous hand tightening. A pressure assisted sealing piston provides a leak tight seal. The quick connection to the thread is achieved by moving an actuating loop through 90° which simultaneously engages the valve threads, sealing piston and a safety mechanism that prevents disconnection under pressure.



The WEH[®] Conversion kits are designed for upgrading existing filling rigs. Both 200 bar and 300 bar versions are available. The quick connectors are also available for upgrading hose filling systems.

FASTER TESTING OF RESPIRATORY PROTECTIVE EQUIPMENT WITH THE TW156 QUICK CONNECTOR

SCBAs used by fire brigades must be regularly function tested.

In order to speed up this test procedure, WEH has added the TW156 quick connector to its product range of BA products.

The lever actuated TW156 connects in seconds to the manual inlet valve of the respiratory protective device eliminating repetitive turning. By simply actuating the hand lever and placing the connector onto the inlet valve, then releasing the hand lever, the pressure medium can be applied.

To disconnect, simply actuate the hand lever and remove the TW156.

The TW156 quick connector is designed to suit max. 300 bar BA sets. It can either be mounted directly or connected by hose to the existing test unit. When used with a hose, the connector must be securely anchored when not in use.

TW156 is available with manual or pneumatic actuation.



» WEH® Connectors for breathing air

ILLUSTRATIONS



Existing BA cylinder filling rig after it has been upgraded to using the **CLICKMATE® TW154**



Testing of respiratory equipment with TW156 quick connector

» CLICKMATE® TW154 | Upgrading existing filling rigs

DESCRIPTION



Features

- Connection directly to the standard threads of the cylinder valves
- Quick connection in seconds without hand tightening
- Filling of breathing air cylinders becomes even easier and more efficient
- Improves operational safety and ergonomics

CLICKMATE® TW154 quick connector is designed for filling breathing air cylinders. Existing filling rigs equipped with screw connectors can be upgraded without problems.

The CLICKMATE® TW154 uses the split collet thread design that locks securely into standard threads of cylinder valves. Connection is made by lowering the operating loop through 90° which locks the split collet jaws into the cylinder valve and actuates the sealing piston. An integrated safety mechanism prevents disconnection under pressure.

CLICKMATE® TW154 is available for 200 bar systems (designated by a black lever) and 300 bar systems (designated by a red lever).

All connectors are subjected to extensive pressure and durability tests.

Application

Quick connector for filling of BA cylinders in fire brigade BA filling installations for direct connection to existing filling rigs that have balancers to equalize weight and height.

TECHNICAL DATA

Characteristics	Basic version	Options
Pressure range	PN = 200 bar PS = 250 bar PT = 375 bar PN = 300 bar PS = 375 bar PT = 565 bar	On request
Temperature range	+5 °C up to +70 °C	On request
Medium	Breathing air (compressed air)	On request
Connection A (cylinder valve)	Standard connection for G5/8" internal thread (DIN 477)	Other connections acc. to the corresponding national standard available. Special connections available.
Inlet B1	Depending on connection at the filling rig	On request
Material	Brass and corrosion-resistant stainless steel	On request
Sealing material	FKM / NBR	On request

» CLICKMATE® TW154 | Upgrading existing filling rigs

SYSTEM OVERVIEW

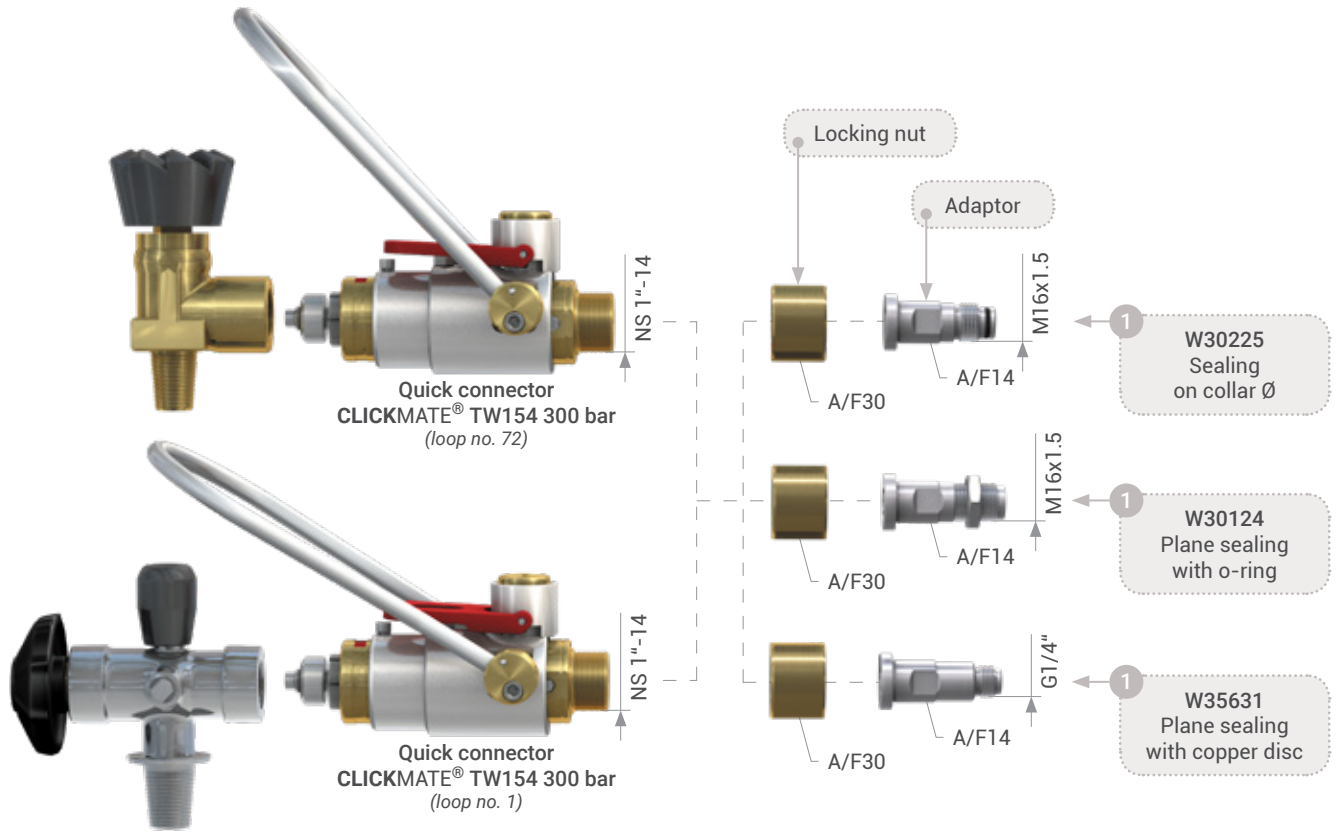

Filling rig with CLICKMATE® TW154 Connectors

» CLICKMATE® TW154 | Upgrading existing filling rigs

ORDERING | Quick connector CLICKMATE® TW154 with operating loop no. 72

approx. dimensions (mm)

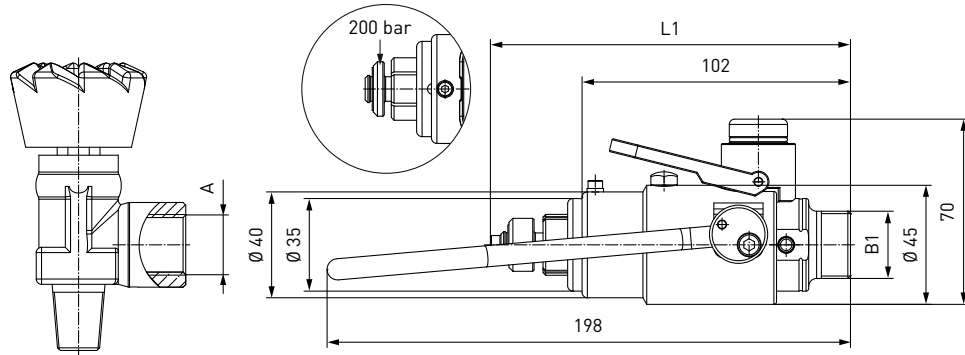

Part No.	Description	Pressure (PN)	A (internal thread)	B1 (external thread)	L1
C1-92774-X01	CLICKMATE® TW154 (black lever)	200 bar	G5/8"*	NS 1"-14	126
C1-92775-X01	CLICKMATE® TW154 (red lever)	300 bar	G5/8"*	NS 1"-14	136
E51-308S508	Spare front seal for CLICKMATE® TW154	-	-	-	-

* acc. to DIN 477

ORDERING | Quick connector CLICKMATE® TW154 with operating loop no. 1

approx. dimensions (mm)

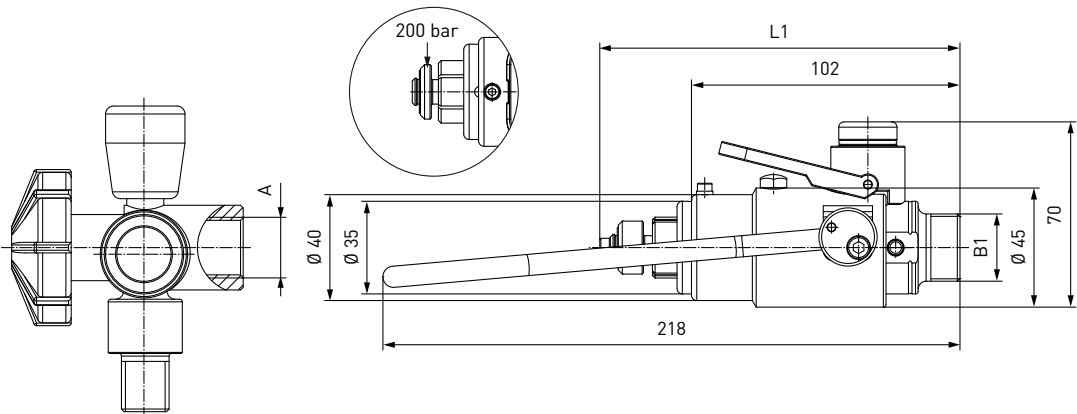

Part No.	Description	Pressure (PN)	A (internal thread)	B1 (external thread)	L1
C1-109695-X01	CLICKMATE® TW154 (black lever)	200 bar	G5/8"*	NS 1"-14	126
C1-109696-X01	CLICKMATE® TW154 (red lever)	300 bar	G5/8"*	NS 1"-14	136
E51-308S508	Spare front seal for CLICKMATE® TW154	-	-	-	-

* acc. to DIN 477

» CLICKMATE® TW154 | Upgrading existing filling rigs

ACCESSORIES

The following accessories are available for the **CLICKMATE®** TW154:

1 Adaptor incl. locking nut

Adaptor for **CLICKMATE®** TW154 for connection to the filling rig.



Part No.	Description	Pressure	Connection
W30225	For connection to the filling rig	200 bar / 300 bar	M16x1.5 external thread o-ring sealing on collar Ø 12.9 mm
W30124	For connection to the filling rig	200 bar / 300 bar	M16x1.5 external thread o-ring plane sealing
W35631	For connection to the filling rig	200 bar / 300 bar	G1/4" external thread plane sealing

2 Weight and height balancing system TZ100

For safe positioning of the cylinders below the filling rig.

Note: Please note that a minimum space of 180 mm from connector centre to connector centre has to be observed at the filling rig!



Part No.	Description	Filling height
C1-66042	TZ100 System 1	825 - 870 mm
C1-66237	TZ100 System 2	840 - 910 mm
C1-66238	TZ100 System 3	880 - 980 mm
C1-66239	TZ100 System 4	955 - 1055 mm

» CLICKMATE® TW154 | Direct connection to hose filling systems

DESCRIPTION

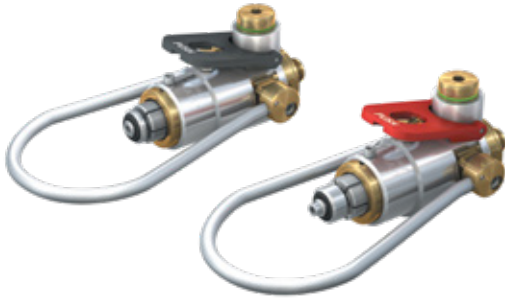

Features

- Connection directly to the standard threads of the cylinder valves
- Quick connection in seconds without hand tightening
- Filling of breathing air cylinders becomes even easier and more efficient
- Improves operational safety and ergonomics

CLICKMATE® TW154 quick connector is designed for filling respiratory air cylinders. Existing connectors for hose filling can be upgraded without problems.

The CLICKMATE® TW154 uses the split collet thread design that locks securely into standard threads of cylinder valves. Connection is made by lowering the operating loop through 90° which locks the split collet jaws into the cylinder valve and actuates the sealing piston. An integrated safety mechanism prevents disconnection under pressure.

CLICKMATE® TW154 is available for 200 bar systems (designated by a black lever) and 300 bar systems (designated by a red lever).

All connectors are subjected to extensive pressure and durability tests.

Application

Quick connector for filling of BA cylinders in fire brigade BA filling installations for direct connection to hose filling systems.

TECHNICAL DATA

Characteristics	Basic version	Options
Pressure range	PN = 200 bar PS = 250 bar PT = 375 bar PN = 300 bar PS = 375 bar PT = 565 bar	On request
Temperature range	+5 °C up to +70 °C	On request
Medium	Breathing air (compressed air)	On request
Connection A (cylinder valve)	Standard connection for G5/8" internal thread (DIN 477)	Other connections acc. to the corresponding national standard available. Special connections available.
Inlet B1	Depending on connection at the filling hose	On request
Material	Brass and corrosion-resistant stainless steel	On request
Sealing material	FKM / NBR	On request

» CLICKMATE® TW154 | Direct connection to hose filling systems

SYSTEM OVERVIEW

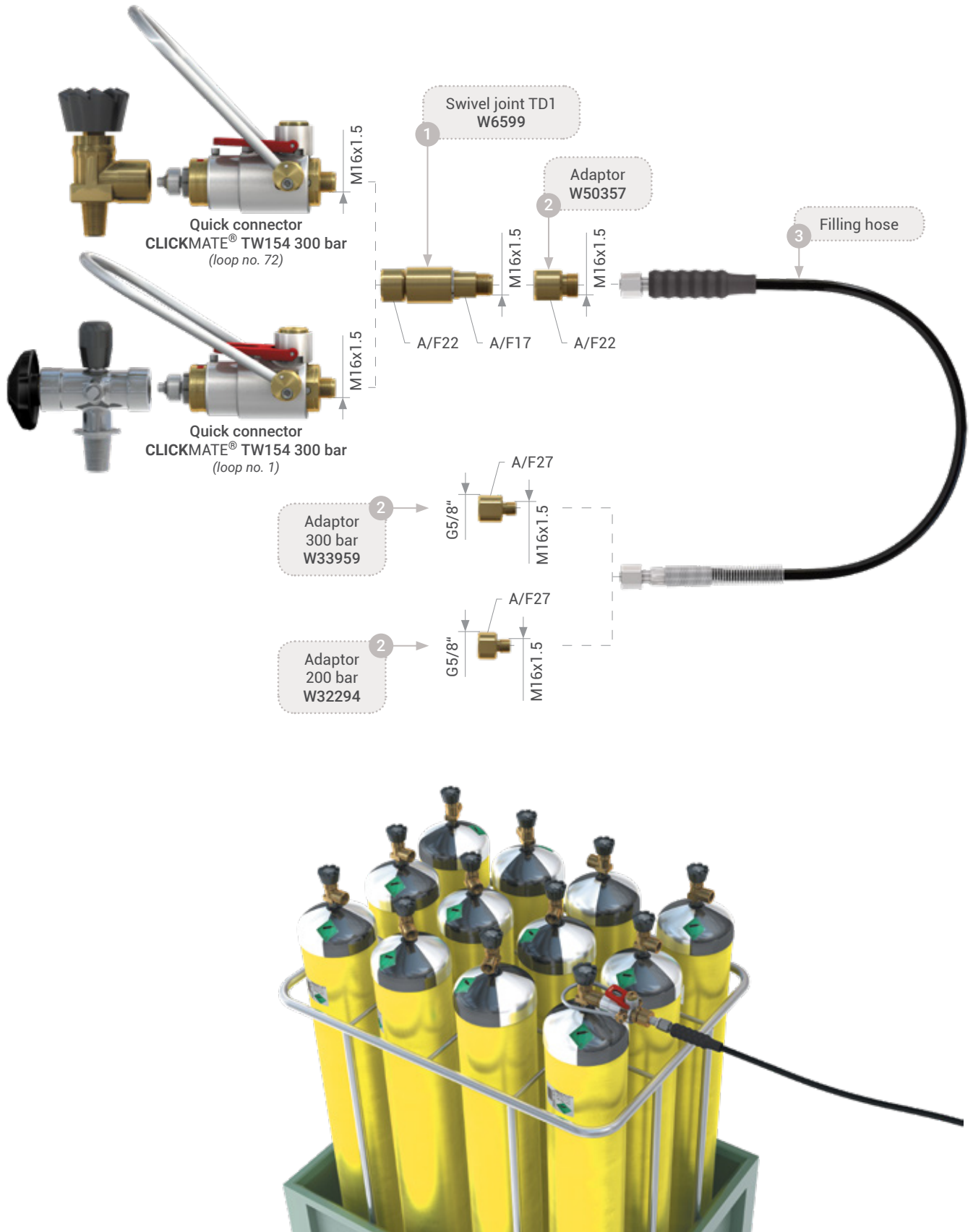

Hose filling system with CLICKMATE® TW154

» CLICKMATE® TW154 | Direct connection to hose filling systems

ORDERING | Quick connector CLICKMATE® TW154 with operating loop no. 72

approx. dimensions (mm)

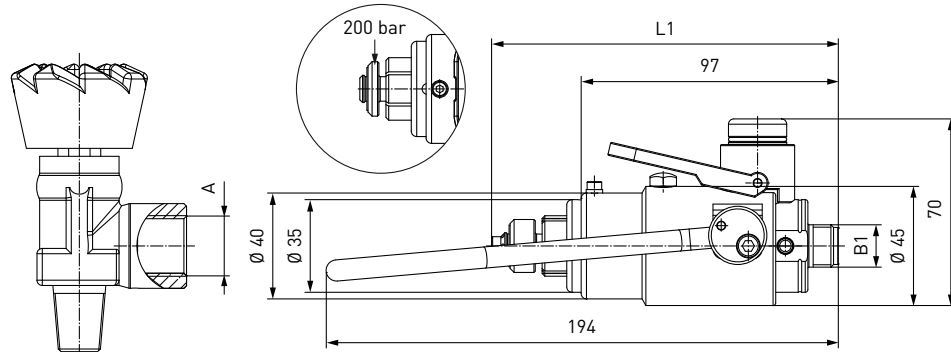

Part No.	Description	Pressure (PN)	A (internal thread)	B1 (external thread)	L1
C1-92776-X01	CLICKMATE® TW154 (black lever)	200 bar	G5/8"*	M16x1.5	122
C1-92777-X01	CLICKMATE® TW154 (red lever)	300 bar	G5/8"*	M16x1.5	131
E51-308S508	Spare front seal for CLICKMATE® TW154	-	-	-	-

* acc. to DIN 477

ORDERING | Quick connector CLICKMATE® TW154 with operating loop no. 1

approx. dimensions (mm)

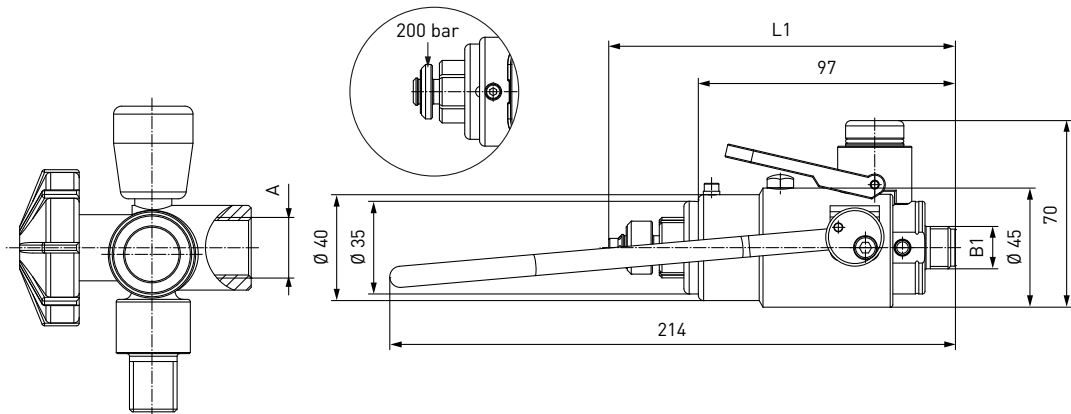

Part No.	Description	Pressure (PN)	A (internal thread)	B1 (external thread)	L1
C1-109697-X01	CLICKMATE® TW154 (black lever)	200 bar	G5/8"*	M16x1.5	122
C1-109698-X01	CLICKMATE® TW154 (red lever)	300 bar	G5/8"*	M16x1.5	131
E51-308S508	Spare front seal for CLICKMATE® TW154	-	-	-	-

* acc. to DIN 477

» CLICKMATE® TW154 | Direct connection to hose filling systems

ACCESSORIES

The following accessories are available for the **CLICKMATE®** TW154:

1 Swivel joint TD1

The swivel joint TD1 prevents twisting of the hose and enables the axial aligning of the connector.



Part No.	Description	Pressure	Connection
W6599	Swivel joint TD1	200 bar / 300 bar	M16x1.5 external thread
B200B-049-00	Seal set for TD1	-	-

2 Adaptor

Adaptor for connection to the filling hose resp. for connection of the filling hose with the filling rig.



Part No.	Description	Pressure	Connection
W50357	For connection to the filling hose	200 bar / 300 bar	M16x1.5 external thread o-ring with 60° inner cone
W32294	For connection filling hose / filling rig	200 bar	G5/8" internal thread <i>DIN 477 No. 13</i>
W33959	For connection filling hose / filling rig	300 bar	G5/8" internal thread <i>DIN 477 No. 16</i>

3 Filling hose



Part No.	Description	Connection
E68-32040	Hose length 1.5 m / Nominal bore DN 5 mm (incl. TÜV approval)	M16x1.5 internal thread

Other hose lengths on request

» CLICKMATE® TW154 | Filling twin cylinder packs

DESCRIPTION

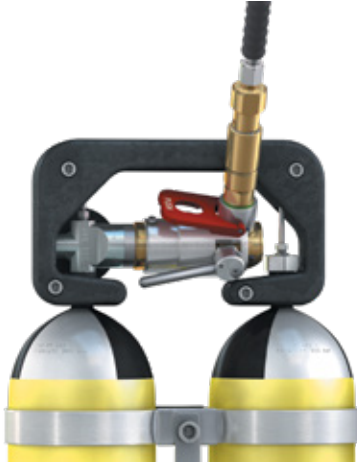

Features

- Suitable for rigidly mounted twin cylinder packs
- 90° media inlet
- Quick connection in seconds without hand tightening
- Improves operational safety and ergonomics

A special version of the **CLICKMATE® TW154** quick connector enables easy filling of rigidly mounted twin cylinder packs. Normally the filling hose has to be screwed manually into the cylinder valve, but now the screw connectors used can be replaced with the **CLICKMATE® TW154** connector.

The lateral 90° media inlet of the **CLICKMATE® TW154** enables the connector to be easily positioned within the carrying handle of the cylinder pack and then connected to the cylinder valve. An integrated swivel joint helps to align the WEH® connector to the valve, thus eliminating hose twisting. The **CLICKMATE® TW154** uses the split collet thread design that locks securely into standard threads of cylinder valves. The split collet design system locks securely and the connection is made by lowering the lateral operating lever through 90°, locking the split jaws into the cylinder valve and actuating the sealing piston. An integrated safety mechanism prevents disconnection under pressure.

CLICKMATE® TW154 is available for 200 bar systems (designated by a black lever) and 300 bar systems (designated by a red lever).

All connectors are subjected to extensive pressure and durability tests.

Application

Quick connector for filling of BA twin cylinder packs in fire brigade BA filling installations for direct connection to hose filling systems.

TECHNICAL DATA

Characteristics	Basic version	Options
Pressure range	PN = 200 bar PS = 250 bar PT = 375 bar PN = 300 bar PS = 375 bar PT = 565 bar	On request
Temperature range	+5 °C up to +70 °C	On request
Medium	Breathing air (compressed air)	On request
Connection A (cylinder valve)	Standard connection for G5/8" internal thread (DIN 477)	Other connections acc. to the corresponding national standard available. Special connections available.
Inlet B1	Depending on connection at the filling hose	On request
Material	Brass and corrosion-resistant stainless steel	On request
Sealing material	FKM / NBR	On request

» CLICKMATE® TW154 | for filling twin cylinder packs

SYSTEM OVERVIEW

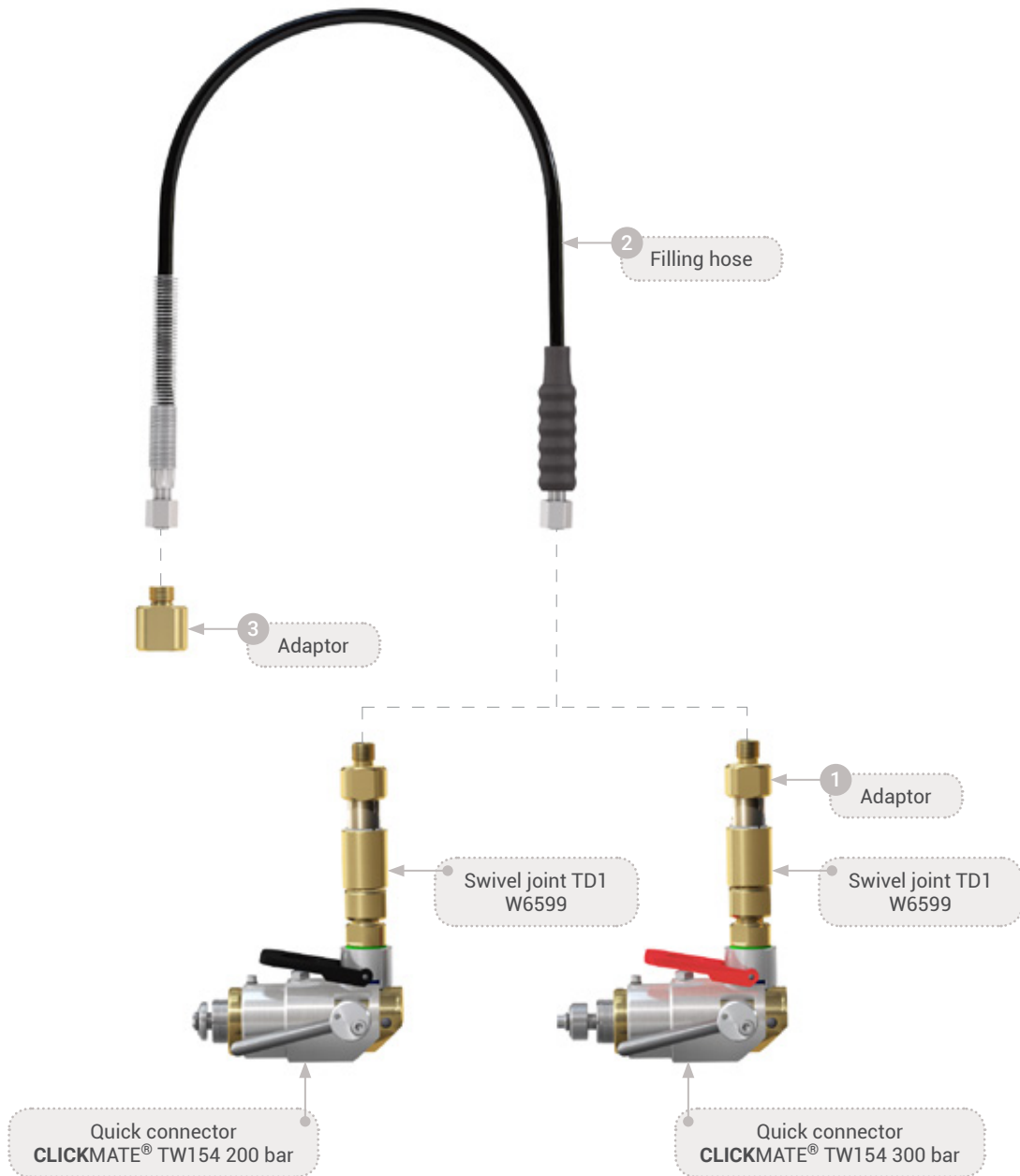

» CLICKMATE® TW154 | for filling twin cylinder packs

ORDERING | Quick connector CLICKMATE® TW154

approx. dimensions (mm)

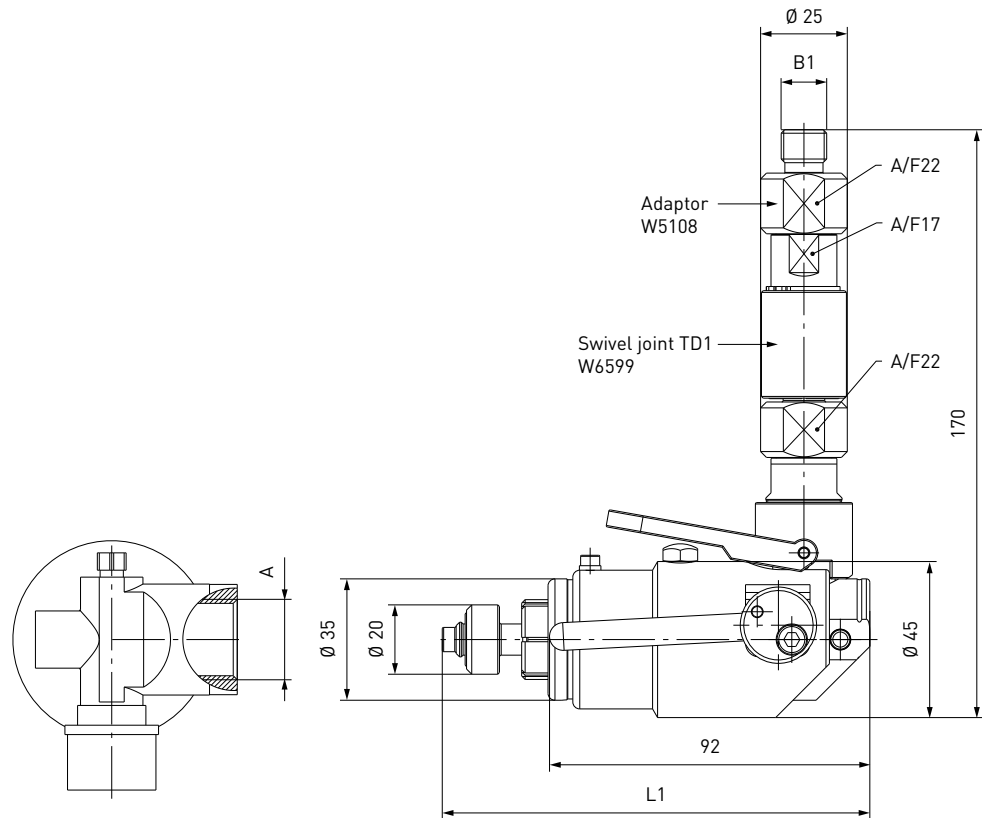

Part No.	Description	Pressure (PN)	A (internal thread)	B1 (external thread)	L1
C1-93101-X01	CLICKMATE® TW154 (black lever) incl. swivel joint TD1 (W6599) and adaptor (W5108)	200 bar	G5/8"*	G1/4" with 60° inner cone	111
C1-89990-X01	CLICKMATE® TW154 (red lever) incl. swivel joint TD1 (W6599) and adaptor (W5108)	300 bar	G5/8"*	G1/4" with 60° inner cone	123
E51-308S508	Spare front seal for CLICKMATE® TW154	-	-	-	-
B200B-049-00	Seal set for TD1	-	-	-	-

* acc. to DIN 477

On request the CLICKMATE® TW154 quick connector for twin cylinder packs is also available without swivel joint and adaptor. Please contact us!

» CLICKMATE® TW154 | for filling twin cylinder packs

ACCESSORIES

The following accessories are available for the CLICKMATE® TW154:

1 Adaptor

Adaptor W50357 has to be used for hose filling when using the filling hose (2).



Part No.	Description	Pressure	Connection
W50357	For connection to the filling hose	200 bar / 300 bar	M16x1.5 external thread o-ring with 60° inner cone

2 Filling hose



Part No.	Description	Connection
E68-32040	Length 1.5 m / nominal bore DN 5 mm (incl. TÜV approval)	M16x1.5 internal thread

Other hose lengths on request

3 Adaptor

Adaptor for connection of the filling hose with the filling rig.



Part No.	Description	Pressure	Connection
W32294	For connection filling hose / filling rig	200 bar	G5/8" internal thread <i>DIN 477 No. 13</i>
W33959	For connection filling hose / filling rig	300 bar	G5/8" internal thread <i>DIN 477 No. 16</i>

» CLICKMATE® | Versions

Of course there are many other versions of our CLICKMATE® Connectors available, e.g. with operating lever, venting valve or check valve.

And WEH also offers quick connectors for other standards, for example the CGA standard.

That's only a small variety of special connectors. Please do not hesitate to contact us for other versions!

CLICKMATE® TW154 WITH VENTING VALVE FOR INTERNAL THREADS



- Standard connection for G5/8" internal thread (*DIN 477*)
- Inlet B1: UNF 7/16"-20 external thread (adaptor)
- Pressure range: PN = 300 bar | PS = 375 bar | PT = 565 bar
- Lateral operating lever
- Integrated venting valve
- Integrated adaptor on the media inlet
- Other designs on request

CLICKMATE® TW154 WITH VENTING AND CHECK VALVE FOR INTERNAL THREADS

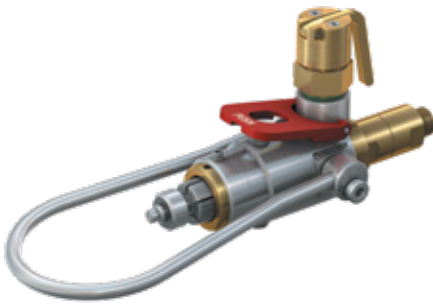

- Standard connection for G5/8" internal thread (*DIN 477*)
- Inlet B1: M16x1.5 external thread (check valve)
- Pressure range: PN = 300 bar | PS = 375 bar | PT = 565 bar
- Operating loop
- Integrated venting valve
- Integrated check valve on the media inlet
- Other designs on request

» CLICKMATE® | Versions

CLICKMATE® TW157 WITH LEVER FOR EXTERNAL THREADS



- Standard connection for 0.825"-14 NGO-RH external thread (CGA 346/347)
- Inlet B1: NS 1"-14 external thread
- Pressure range: PN = 280 bar | PS = 350 bar | PT = 525 bar
- Lateral operating lever
- Optional with integrated venting valve
- Other designs on request

CLICKMATE® TW157 WITH LOOP FOR EXTERNAL THREADS

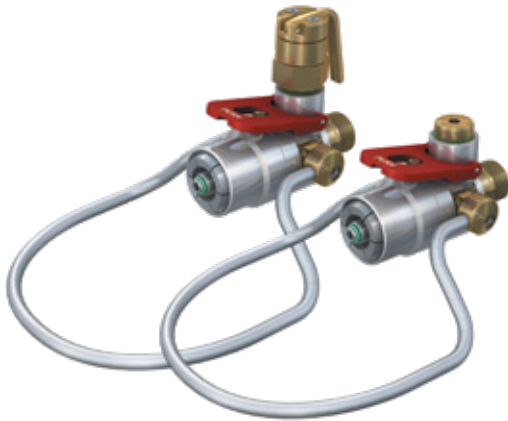

- Standard connection for 0.825"-14 NGO-RH external thread (CGA 346/347)
- Inlet B1: NS 1"-14 external thread
- Pressure range: PN = 280 bar | PS = 350 bar | PT = 525 bar
- Operating loop
- Optional with integrated venting valve
- Other designs on request

CLICKMATE® TW157 WITH LOOP FOR EXTERNAL THREADS (W22X1/14")

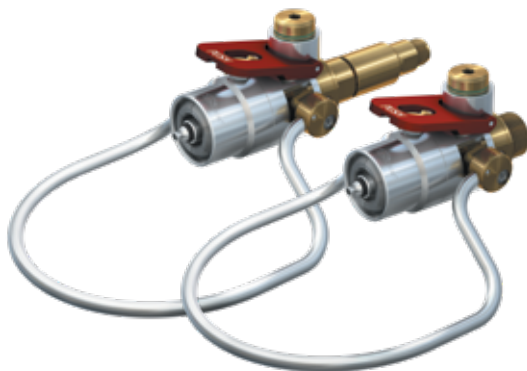

- Standard connection for W22x1-14" external thread
- Inlet B1: NS 1"-14 external thread resp. M16x1.5 external thread (TD1)
- Pressure range: PN = 150 bar | PS = 188 bar | PT = 285 bar or PN = 300 bar | PS = 375 bar | PT = 565 bar
- Operating loop
- Available with or without swivel joint type TD1 on the media inlet
- Other designs on request

» WEH® Connector TW156 | For respiratory protective equipment

DESCRIPTION



Features

- Quick connection in seconds without hand tightening
- Robust design
- Easy connection means no straining of muscles, joints, etc.
- Improves operational safety and ergonomics

The WEH® TW156 Quick connector can be connected to the manual inlet valve of the respiratory protective device without hand tightening. The clamping jaws grip into the thread and the pressure-tight connection is made within seconds. The quick connector may either be mounted directly to the existing test unit or connected by a hose to the test unit. When used with a hose, the connector must be securely anchored when not in use.

The TW156 quick connector simplifies testing procedures and shortens test times and is available with manual or pneumatic actuation.

Application

Quick connector for testing respiratory protective equipment up to max. 300 bar.



Connection to SCBAs of fire brigades



Connection to special test unit



Sample of test unit and SCBA

TECHNICAL DATA

Characteristics	Basic version	Options
Pressure range	PN = 300 bar PS = 375 bar PT = 565 bar	PN = 200 bar PS = 250 bar PT = 375 bar
Pilot pressure	6 - 12 bar	On request
Temperature range	+5 °C up to +70 °C	On request
Medium	Air	On request
Connection A (respiratory protective equipment)	G5/8" external thread acc. to DIN 477-5 (300 bar)	G5/8" external thread acc. to DIN 477-1 (200 bar)
Pilot pressure port P1	G1/8" internal thread	On request
Pilot pressure port P2	G1/4" internal thread	On request
Actuation	H = manual actuation of the lever V = actuation via pneumatic / manual finger pressure valve P = pneumatic actuation for automated applications and activations	On request
Material	Corrosion-resistant stainless steel Extensions: chromed / brass	On request
Sealing material	NBR	On request

» WEH[®] Connector TW156 | For respiratory protective equipment

SYSTEM OVERVIEW

For the TW156 various actuations and extensions are available. The following diagram shows the different versions.

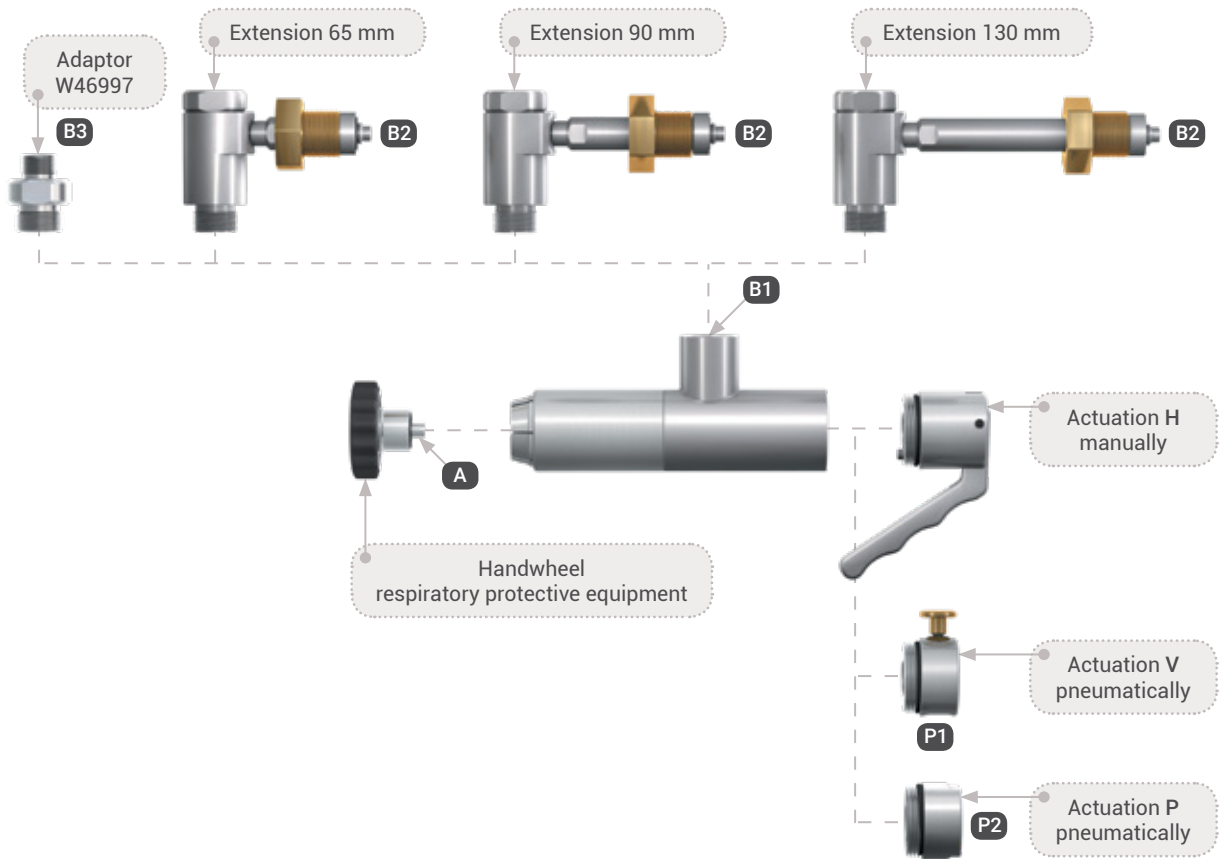

Port definition

- A** Connection respiratory protective equipment
- B1** Media inlet
- B2** Media inlet on versions with extension
- B3** Media inlet on versions with adaptor for filling hose G1/2" - M16x1.5
- P1** Pilot pressure line (actuation V)
- P2** Pilot pressure line (actuation P)

» WEH® Connector TW156 | For respiratory protective equipment

ORDERING | Quick connector TW156 with extension 90 / 130 mm for SCBA with carrying system

approx. dimensions (mm)

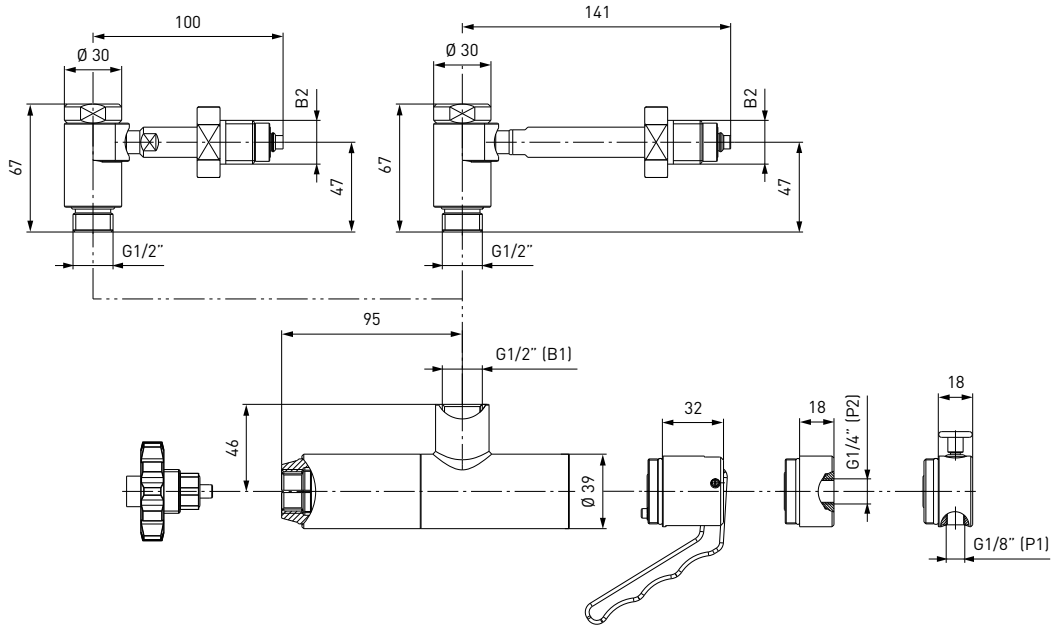

MSA Multicheck / Proficheck



Part No.	Description	Pressure (PN)	Actuation	B2 (external thread)
C1-33718	Elbow extension 130 mm	300 bar	Manually H	G5/8"
C1-55849	Elbow extension 130 mm	300 bar	Pneumatically P	G5/8"
C1-75998	Elbow extension 130 mm	300 bar	Pneumatically V	G5/8"
C1-55640	Elbow extension 90 mm	300 bar	Manually H	G5/8"
C1-88567	Elbow extension 90 mm	300 bar	Pneumatically P	G5/8"
C1-94723	Elbow extension 90 mm	300 bar	Pneumatically V	G5/8"

ORDERING | Quick connector TW156 with extension 65 mm for SCBA with carrying system

approx. dimensions (mm)

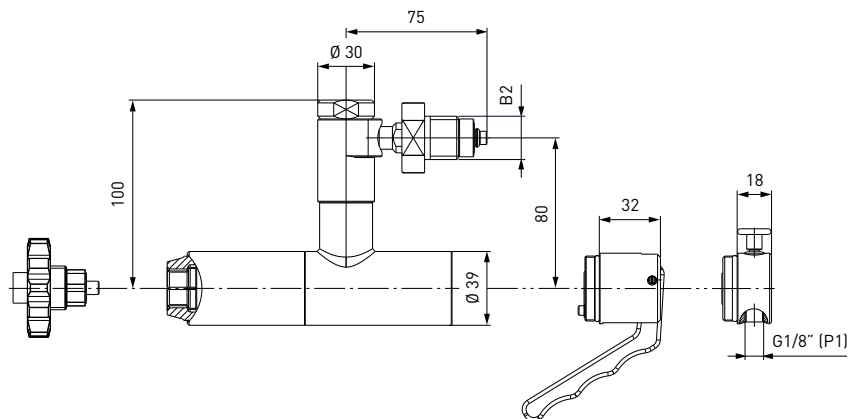

Dräger Quaestor III / Quaestor automatic



Part No.	Description	Pressure (PN)	Actuation	B2 (external thread)
C1-35615	Elbow extension 65 mm	300 bar	Manually H	G5/8"
C1-67670	Elbow extension 65 mm	300 bar	Pneumatically V	G5/8"

» WEH[®] Connector TW156 | For respiratory protective equipment

ORDERING | Quick connector TW156 for SCBA

approx. dimensions (mm)

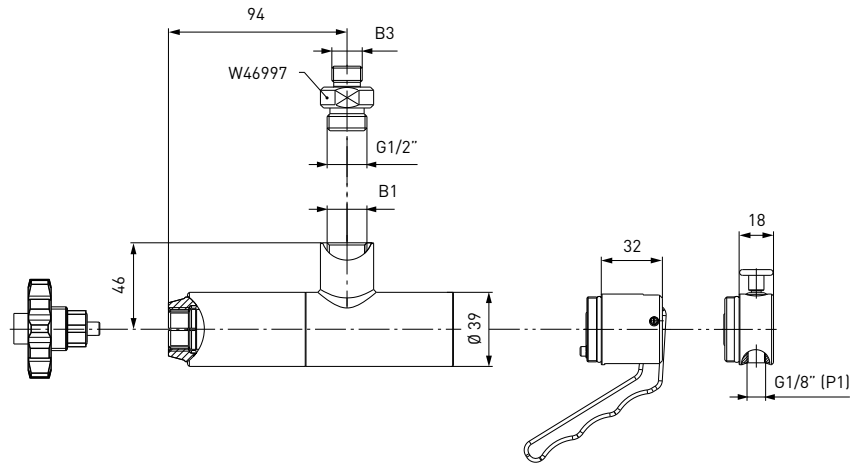

Part No.	Description*	Pressure (PN)	Actuation	B1 (internal thread) / B3 (external thread)
C1-18581	Without elbow extension (Labtec 100)	300 bar	Pneumatically V	G1/2"
C1-33939	Without elbow extension	300 bar	Manually H	G1/2"
C1-47019	Incl. adaptor W46997; without elbow extension	300 bar	Manually H	G1/2" (B1) / M16x1.5 (B3)

* hoses not included

» Technical appendix

Definitions

Abbreviation	Definition	
Pressure specifications		
PN	Nominal pressure	Nominal pressure after temperature compensation at 15 °C
PS	Max. allowable operating pressure	Maximum allowable operating pressure acc. to Pressure Equipment Directive 2014/68/EU, Article 2 paragraph 8
PT	Hydrostatic test pressure	Hydrostatic test pressure acc. to Pressure Equipment Directive 2014/68/EU, Annex I no. 7.4
PP	Pilot pressure	Actuation pressure for hydraulic and pneumatic components
PC	Cracking pressure	Pressure at which the check valve opens and the first indication of flow occurs
MAWP	Max. allowable working pressure	Max. allowable operating pressure at which the weakest point of the system or the vessel (e.g. cylinder valve) can operate at a certain temperature during normal operation.
Dimensions		
L1, L2, L3 ...	Length specification	
D1, D2, D3 ...	Diameter specification	
A/F(1), A/F(2) ...	Wrench size specification	
Ports		
A / X	Customer-specific port (test piece, sample, cylinder valve, handwheel respiratory protective equipment)	
B1, B2, B3 ...	Media ports	
C1, C2, C3 ...	Gas recirculation ports	
P1, P2, P3 ...	Pilot pressure ports	
M	Measuring port	
Q	Drain port filter	
G	Mounting bores	
Others		
DN	Nominal bore	
µm	Max. diameter of the filtered particle	
Kv	Is the discharge of water in m ³ /h at a pressure drop of 1 bar, acc. to DIN/EN 60534-2	
Cv	Is the discharge of water in gallons per minute at a pressure drop of 1 psi, acc. to DIN/EN 60534-2	
IR	Infrared data interface	
ENR	Exchangeable data interface (exchangeable nozzle receiver)	
TS	Maximum allowable temperature acc. to Pressure Equipment Directive 2014/68/EU, Article 2 paragraph 9	
Breakaway force	Is the force range, in which the breakaway releases	
NC	Normally closed (initial position of shut-off valve)	
NO	Normally open (initial position of shut-off valve)	

» Technical appendix

Technical explanations

Term	Definition
Temperature range	Is the temperature range in which the WEH® Product can be used.
Media temperature range	Is the temperature range of the medium used, which can flow through the WEH® Product (may change depending on the time of measurement).
Ambient temperature range	Is the temperature range of the environment in which the WEH® Product can be used.
Leak rate	Is the leak rate, which the WEH® Product max. exhibits under intended use.
Max. side load	<p>Is the max. allowable sum of all external forces that may act on the device under intended use.</p> <p>Note: External forces can affect the life time of WEH® Products and can cause damage. Tensile and transverse loads as well as vibrations and pressure impacts need to be considered, e.g. by user side measures such as on site mountings and similar. Therefore, lateral forces such as whipping hoses or other equipment must be avoided. WEH® Products should be installed in such a way, that lateral forces which could lead to leakage or damage can not occur. Special applications require a special consultation before selecting the product.</p>
Products with pneumatic actuation	The customer has to ensure there is adequate axial movement when pneumatically actuated WEH® Products are used in automated systems, see maximum side load. Ideally the products should be mounted with a floating joint or introduced individually to prevent the possibly existing clamping jaws getting blocked or jammed in the thread of the test piece.
Sealing material	<p>On request the WEH® Product can be adapted to customer specific applications regarding to the sealing materials used.</p> <p>The clarification of the media compatibility and suitability of the adapted WEH® Product for the final application is always the responsibility of the end user.</p>
Storage / life time of components	There are certain requirements for every WEH® Product. These are described in the corresponding product documentation.

Further explanations

Subject	Definition
Safe product selection	<p>Our WEH® Products are designed to be operated by qualified professional users (insofar as WEH® Products are also designed to be operated by other users in individual cases, this is explicitly stated in the corresponding operating instructions). You alone are responsible for the selection of WEH® Products and their configuration according to the requirements of your system. In doing so, please particularly consider your intended use, your performance data, your material compatibility, your system concept and your system limits as well as your technical and legal requirements for operation, handling and maintenance. The quality and safety of WEH® Products is our highest priority. For this reason, WEH® Products may not be used outside the specifications in the relevant data sheets and product descriptions. We also strongly recommend that you refrain from using third-party spare parts or a combination of WEH® Products with unsuitable third-party products. You alone are responsible for reviewing the suitability of third-party products. WEH® Products and WEH® Spare parts comply with our quality and safety standards.</p>
Explanation on the Pressure Equipment Directive	<p>In general, WEH® Products with a maximum allowable operating pressure of more than 0.5 bar (PS) fall within the scope of application of the Pressure Equipment Directive 2014/68/EU. These WEH® Products are generally and exclusively classified as pressure accessories for piping in accordance with Article 2 (5) of the Pressure Equipment Directive 2014/68/EU. Based on the conducted classification, the conformity with the Pressure Equipment Directive 2014/68/EU is generally established under Article 4 (3) of the Pressure Equipment Directive 2014/68/EU. In these cases, the application of WEH® Products must correspond to their classification as pressure accessories for piping, and they may not be used either (i) as safety accessories or (ii) for vessels within the meaning of the Pressure Equipment Directive 2014/68/EU.</p> <p>For some products a different classification and/or categorisation is required or can be conducted on request. In these cases, a conformity assessment procedure in accordance with Annex III of the Pressure Equipment Directive 2014/68/EU can and will be conducted (if legally required) and the conformity can be declared by means of an EU Declaration of Conformity in accordance with Annex IV of the Pressure Equipment Directive 2014/68/EU. In these cases, the EU Declaration of Conformity is enclosed with the product.</p>

» Technical appendix

Further explanations

Subject	Definition
External change management	WEH reserves the right to update, optimise and adjust its products continuously. This may result in corresponding changes of the product. Customers will be informed proactively or unsolicited by WEH only in individual cases about product updates, product optimisations and/or product adaptations that have been carried out. You are free to contact WEH at any time to request information about any product updates, product optimisations and/or product adjustments.

» Brochure data

This catalogue was created diligently and on the basis of decades of experience.

All information/recommendations in this catalogue are non-binding and are particularly subject to possible deviations or changes. For any binding information/recommendations, please refer to the verified information/recommendations in our individual orders. Particularly, due to the wide range of possible applications of WEH® Products and the unknown parameters and operating conditions linked to them, the accuracy and/or completeness of the information/recommendations in this catalogue cannot be guaranteed with respect to certain individual cases. In doing so, we would like to refer once again to the information/recommendations provided in individual orders.

The application limits indicated in this catalogue (e.g. for pressure, temperature, etc.) are generally theoretical values determined in a test environment. As the concrete operating conditions could differ, we cannot ensure that these values apply to a specific customer application. During the practical use, you should particularly consider that the mutual influence of operational parameters could result in changes of the maximum values. Especially, in case of any unusual operating conditions, please contact WEH before using any WEH® Products. We therefore strongly recommend that you also require any necessary binding information/recommendations to be included by us in the individual orders.

Furthermore, we point out that we cannot assume any warranty or accept any responsibility for printing errors, incomplete information or misinterpretations. Product images are particularly provided for illustrative purposes only. Moreover, dimensions and other technical details in this catalogue are non-binding information and are provided for illustrative purposes only. The product's exact form and design result exclusively from the specific individual order. In particular, certain information/recommendations in the catalogue only become integral part of the contract if they have been expressly contractually agreed.

Only the latest version of our catalogue and other product related documents is valid and applicable. Please ensure that you always use the latest catalogue's and documents' versions. Please feel free to contact WEH at any time and request the latest versions.

In case of deliveries and other services, our General Terms and Conditions and the Know-How Protection and Quality Assurance Agreement shall apply unless otherwise expressly agreed.

As a general rule, please appreciate that we cannot accept the General Terms and Conditions of our customers or third parties. Thank you for your understanding.



» Design and production

Address: **WEH GmbH Precision Connectors**
Josef-Henle-Str. 1
89257 Illertissen / Germany

Internet: www.weh.com
Email: sales@weh.com

Phone: +49 7303 9609-0

For queries and further information, please do not hesitate to contact us.